

HARDWARE & ACCESSORIES

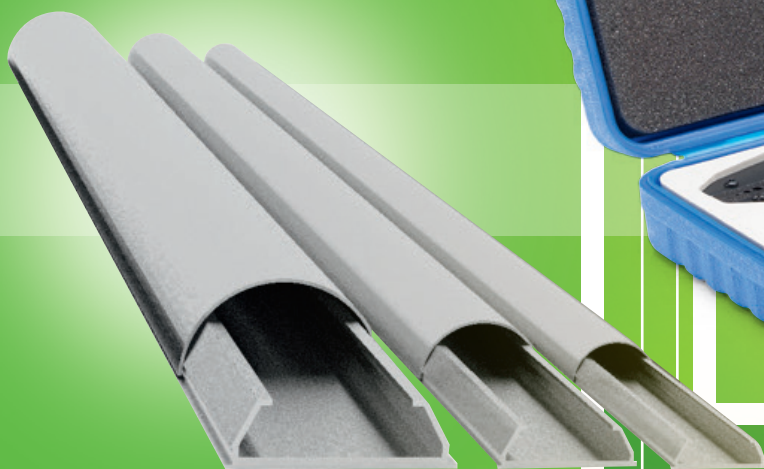
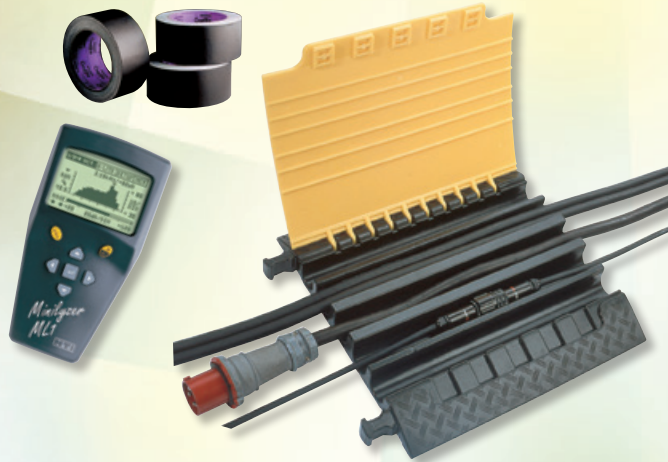

TABLE OF CONTENTS HARDWARE & ACCESSORIES



INSTALLATION COMPONENTS

• Blank panels	501
• Microphone stand	501
• Gooseneck LED	502
• Velcro straps	523
• Mesh hoses	524
• Cable raceways for permanent installation	525
• Mounting brackets for screens and projectors	526
• LED light - LEDLIGHT 2000	533
• Professional fiber toolbox	535
• NTI measuring instruments	536

DISTRIBUTION SYSTEMS/RACKS/REELS

• Adapter MP-PG29	501
• 19" Varios rack slide-in modules	502
• 19" Rack shelves/drawers	502
• 19" Trays	502
• 19" Removable service panels	502
• 19" Panels/blank panels	504
• 19" Panel housings	506
• 19" Stagebox housing	506
• PLUG MAMA Stagebox housing	507
• THE BOXX Stagebox housing	508
• SCHILL Power cable reels	509
• SCHILL Cable reels w. pull ribbon	509
• SCHILL Cable reels/empty reels	510
• Cable reel accessories	511
• Stackable cable reels	512
• SOMMER CABLE cable reels/empty reels	513
• Multicore case reel system	514
• Protective bags for breakouts and LK/MP multi-channel connectors	517

CABLE WINDING EQUIPMENT

• Universal cable winder	514
• Mobile cable winder	515
• Cable guide/deflection pulley	515
• Floor cable dispenser	515
• Desk-mounted cable winder	516
• Cable length counter	516
• Cable crosscut blade for max. 28 mm/1.1" diameter	516

CABLE MANAGEMENT

• Cable protection ducts, cable bridges	517
• Cable tunnel tape	517
• GAFFGUN™ - The floor tape dispenser	518
• Gaffer tapes, warning tapes	520
• Insulation straps	520
• Cable ties	523
• Velcro straps	523
• Nylon split wire looms	523
• Braided sleeving/cable sleeving	524
• Cable raceways for permanent installation	525

CABLE MANUFACTURE

• Gaffer tapes, warning tapes	520
• Electrical insulation tapes	520
• Repair tapes	521
• Insulation tubing PVC	521
• Heat-shrink tubing	521-522
• Velcro straps	523
• Braided sleeving/cable sleeving	524
• Cable cleaner	532
• Insulation strippers	533
• Tools	533
• Ferrules	534
• Silver solder	534
• Crimping pliers	535
• Professional fiber toolbox	535
• Measuring instruments - cable testers	536

Broadcasting / data / multimedia components ▶ **MULTIPIN ADAPTER ⇔ PG29**

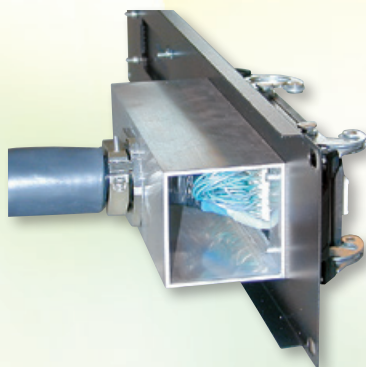
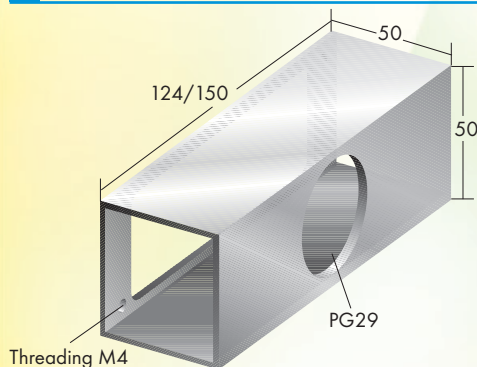

Multi-pin adapters on threaded cable fittings are often required for rear rack wiring. Here a multi-pin housing CHI 16/CHI 24 on 1 x PG29 cable fitting can be wired very nicely.

Size: 50 x 50 x 150 mm/2.0 x 2.0 x 5.9"

ORDER NO.	W x H x D [mm]
MP16-PG29	124 x 50 x 50
MP24-PG29	150 x 50 x 50



x00248

Broadcasting / data / multimedia components ▶ **EMPTY WALL PLATES**

Now you can even buy holes..

... shaped like punched empty blanks and made of robust stainless steel. We offer four different models with universal D-holes and antenna sockets. There are many applications for these blanks: They can either be used as wall plates or table panels, or for conferences. The holes are pre-punched and the plate has a beveled edge of 4 mm/0.16". Dimensions: W x H x D (114 mm x 68 mm x 4 mm/4.5 x 2.7 x 0.16").

ORDER NO.	VERSION
LB1D	1 x universal D-hole
LB2D	2 x universal D-hole
LB1D1A	1 x universal D-hole + cutout for coaxial video connector
LB1A	1 x cutout for coaxial video connector



x00249



LB1D



LB2D



LB1D1A



LB1A

Broadcasting / data / multimedia components ▶ Microphone stand ▶ **ONE-HIDE-STAND**

Here is a ONE-HIDE-STAND without regrets!

You know the problem: You want to adjust the microphone, but the stubborn cable just won't follow? The **ONE-HIDE-STAND**, the microphone stand with a cable guide integrated in the stand, is a practical and elegant solution. The cable is completely hidden and does not interfere.

And the microphone is not screwed in, as is commonly the case, but positioned directly on an innovative XLR adapter with strain relief by Neutrik, omitting the unpractical microphone clamp. Thus, the height of the stand is also variably adjustable in one single step.

The stands both have a robust but slim cast base and an integrated rubber mat that dampens subsonic noises. The cable with Neutrik XLR plug exits on the side. When the stand is extended the cable has a length of 5 meters/16 feet.

APPLICATIONS:

- For studio and gooseneck microphones
- For events in churches, town halls, and conference centers

PRODUCT ADVANTAGES:

- Microphone attachment via XLR connection with integrated strain relief
- Internal cable guide
- Height variable (90 - 160 cm/35.4 - 63") - adjust in one single step
- Clean, organized appearance

ORDER NO.	DESCRIPTION
ONE-HIDE-STAND-2	Single stand with a heavy cast base/ cable outlet on the side
ONE-HIDE-STAND-3	Single stand with a slim cast cast base/ cable outlet on the side



x00250



ONE-HIDE-STAND-2



ONE-HIDE-STAND-3

Multipair system components ▶ **GOOSENECK LAMP****HICON**
CONNECTORS*Like a nosy gosling...*

... these little helpers are bound to crane. We deliver the flexibly adjustable gooseneck with a 3-pole or 4-pole XLR connection and 4 mini LEDs as light source for audio mixing consoles and racks.

ORDER NO.	DESCRIPTION	LENGTH
GNL380-XLR-90	Gooseneck LED lamp (12 V) with angled XLR 3-pole male connection	38 - 39 cm
GNL380-XLR-4P	Gooseneck LED lamp (12 V) with XLR 4-pole male connection	38 - 39 cm



x00251



GNL380-XLR-90

Multipair system components ▶ **VARIOS 19" RACK INSERTS/RACK SHELVES/DRAWERS/SERVICE PANELS**

There are a lot of great rack inserts available on the market for your DVD player, effect unit, or expander. But there is a well known problem: the units are often so light that they slide back and forth during operation!

Now there is a 19" rack insert made by **SOMMER CABLE** with a track, universally adjustable on the side and also the height to hold your device firmly in place. Secures units measuring less than 43 cm/16.9".

The rack insert **VARIOS REF19**, in typical **SOMMER CABLE** charcoal grey, is made of rigid 1.5 mm/0.06" thick steel panel and will support units with a weight of more than 15 kg/33 lbs.

As a simpler version we offer a 19" rack shelf.

And a high quality rack drawer with various features:

Continuous front grip rail, lock with 2 keys, high quality workmanship.

A 2 U foam block is available as an accessory.

The removable service panels are made of solid metal and high quality workmanship.

ORDER NO.	DESCRIPTION	DIMENSIONS		
		HEIGHT	WIDTH	DEPTH
REF19-2U	Rack insert	2 U	440 mm	290 mm
REF19-3U	Rack insert	3 U	440 mm	290 mm
REF19-4U	Rack insert	4 U	440 mm	290 mm
RSB19-1U	Rack shelf	1 U	440 mm	365 mm
RSB19-2U	Rack shelf	2 U	440 mm	365 mm
RSB19-3U	Rack shelf	3 U	440 mm	365 mm
RSB19-4U	Rack shelf	4 U	440 mm	365 mm
RSL19-2U	Drawer	2 U	405 mm	375 mm
RSL19-3U	Drawer	3 U	405 mm	375 mm
RSL19-4U	Drawer	4 U	405 mm	375 mm
RSL19-6U	Drawer	6 U	405 mm	375 mm
RSL-SCH	Foam block for drawer	2 U	400 mm	365 mm
RSL-6MI	Micro-insert for 6 U drawer for 25 microphones			
RSK-U	Service panel, metal	4 U	385 mm (inside)	127 mm (inside)
RSK-6U	Service panel, metal	6 U	422 mm (inside)	215 mm (inside)
RBA19-1U	Rack shelf with drawer	1 U	445 mm	360 mm

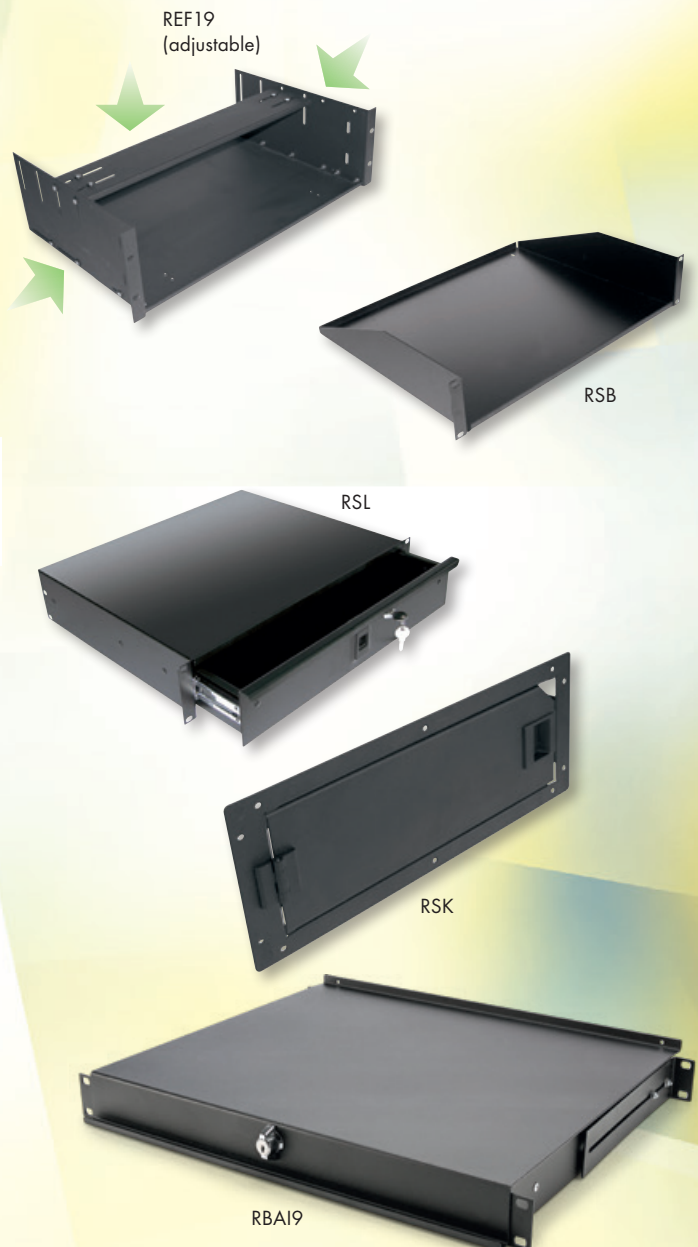

x00253

REF19
(adjustable)

RSB

RSL

RSK

RBA19

Multicore system components ▶ **MODULAR SYSTEMS**

Modular **SYStems** by SOMMER CABLE

Regardless of your area of focus, whether it be live events or systems installation or A/V for conferences and classrooms or the broadcast industry, our broad range of modular SYStems gives you the power to create practically limitless configurations today, and the flexibility to adapt to the latest market standards tomorrow.

SYStem BOXX

The **SYStem** BOXX can be configured as a 19" system or a floor or wall box of variable width and height, and it can also be equipped with 2 U or 3 U front panels. An additional installation level in the middle of the housing permits many different configurations. SYStem BOXX conforms to DIN 41494.



SYStem DESK

Table tank **SYStem** DESK has a robust power-coated full metal casing and can be equipped with 2 U-high front panels and modules up to a maximum of 9 WU (width units). According to DIN 41494, this amounts to 63 DU (depth units). Cable strain relief and dust protection are included.



SYStem BOARD

The wall box – suitable for all SYStem BOXX-components – is configured in such a way that the internal mounting frame is recessed by 100 mm/3.9" so that connectors can stay connected even if the door is closed.



SYStem FLOOR

The floor box insert **SYStem** FLOOR is available in 2 sizes at either 4 or 6 WU, with optional installation of 2 U front panels, compatible with the Ackermann floor box round and square.



SYStem WALL

The **SYStem** WALL system is used for installation of all network, control, multimedia and A/V connections into wall outlet boxes, surface raceways or switch systems as well as all SYStem-module systems.



PRODUCT ADVANTAGES:

- Saves time due to easy installation of pre-configured parts
- Easy to assemble with pre-cut threading and simple inside wiring with ribbon cables
- Fine appearance with counter-sunk screw heads and an attractive dark grey finish
- Clean, individual labeling options
- Clearly structured – 6 different front panel widths
- Absolutely modular (front, rear, side)
- Compact construction (2 U base – even for LK150-pin)
- High rigidity with 2.5 mm/0.1" panel thickness
- Perfect user support with web-configurator under www.sysboxx.com
- 5-year warranty
- Absolute compatibility with DIN 41494 Parts 1, 2 and 5 for integration of components commonly available on the market (Ghielmetti, MHN, Kramer, etc.). 7 DU (depth units) correspond to 1 WU (width unit) on the SYStem BOXX MKII. 19" = 84 DU = 12 WU
- Additional mounting space in 140 mm/5.5" deep wall cabinets – ideal for installation of transformers, electronic components, DIN rail devices, etc.
- Optimized electro-magnetic compatibility for functional safety
- Compliance with the RoHS directive

For detailed information and overview charts, see the chapter "Modular Systems".

Multicore system components ▶ 19" PANELS

A 19" panel is not just...

... a "piece of steel with holes in it", but an important utensil for rack wiring in media technology and stage work. These panels should not just provide a decent cladding and an indestructible coating, but must also be constructed so they manifest sturdiness and strength when exposed to heavy strain and pressure. The front panels are made of black (PBS series...) or charcoal grey (PBA series...) powder-coated 1.2 mm or 2 mm/0.05" or 0.08" sheet steel (depending on version). A U-profile on the top and bottom edges provides added rigidity.

The optional strain relief clamp (order number ZEPB) can be used to reduce pressure on the cables on the back. For labeling, we recommend our writable magnetic strip (Order No. ZSPB) or number strip (Order No. NSPB...).

The Broadcast series (PBQ...) is made of 4 mm/0.16" anodized aluminum sheet which is braced by a stainless steel bracket on the rear and equipped with a strain relief clamp. As a matter of principle, the connectors are always mounted from the rear (for this purpose the panels are milled from behind). Lettering is possible with the SYSBOXX SYPS-03-MK2 labeling profile.

Of course, we can also produce custom models. Please contact us by fax or e-mail (info@sommercable.com) with details of your project.

Blank rack panel

Empty panel for covering, filling out or DIY assembly

ORDER NO.	PANEL THICKNESS	COLOR	HEIGHT	WEIGHT [kg]
PBS0-L	1.2 mm, steel	black	0.5 U	0.250
PBS1-L	1.2 mm, steel	black	1 U	0.500
PBS2-L	1.2 mm, steel	black	2 U	1.500
PBS3-L	1.2 mm, steel	black	3 U	2.000
PBS4-L	1.2 mm, steel	black	4 U	2.500



x00254

**Rack panel, with brushes for cable inlet**

With integrated strain relief

ORDER NO.	PANEL THICKNESS	COLOR	HEIGHT	WEIGHT [kg]
PBS1-KB1	1.2 mm, steel	black	1 U	0.335



x00257

**Rack panel, with brushes for cable inlet**

For retrofit, strain relief possible with ZEPB

ORDER NO.	PANEL THICKNESS	COLOR	HEIGHT	WEIGHT [kg]
PBS1-KA1	1.2 mm, steel	black	1 U	0.335

**Rack panel, for ventilation**

Ventilation panel with air vents, with ventilation slots

ORDER NO.	PANEL THICKNESS	COLOR	HEIGHT	WEIGHT [kg]
PBS1-A	1.2 mm, steel	black	1 U	0.160
PBS2-A	1.2 mm, steel	black	2 U	0.260
PBS3-A	1.2 mm, steel	black	3 U	0.380
PBS4-A	1.2 mm, steel	black	4 U	0.500



x00259

**Rack panel, for ventilation, with fan spaces**

Ventilation panel with air vents, see illustration

ORDER NO.	VERSION	PANEL THICKNESS	COLOR	HEIGHT	WEIGHT [kg]
PBS3-A1	1 fan	1.2 mm, steel	black	3 U	0.660
PBS3-A2	2 fans	1.2 mm, steel	black	3 U	0.540
PBS3-A3	3 fans	1.2 mm, steel	black	3 U	0.420



x00260

**Rack panel, universal D series cutouts**

for XLR, phone jacks, Speakon NL4MP, BNC, etc.

ORDER NO.	VERSION	PANEL THICKNESS	COLOR	HEIGHT	WEIGHT [kg]
PBS1-D08	8-hole	1.2 mm, steel	black	1 U	0.300
PBS1-D12	12-hole	1.2 mm, steel	black	1 U	0.140
PBS1-D16	16-hole	1.2 mm, steel	black	1 U	0.130
PBS2-D16	16-hole	1.2 mm, steel	black	2 U	0.210
PBS2-D24	24-hole	1.2 mm, steel	black	2 U	0.200
PBS2-D32	32-hole	1.2 mm, steel	black	2 U	0.240



x00262

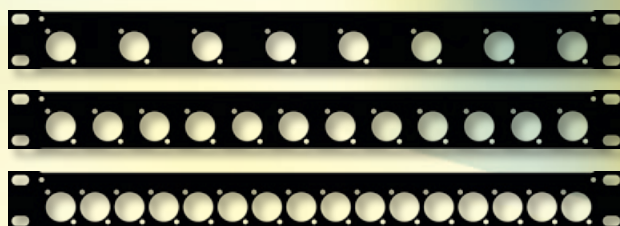

Rack panel, with multipin die-cut

With die-cuts for multipin connectors from Harting, Ilme, etc., without an adapter panel the PBS2-MP version can be fitted with CHI 16 or CHI 24.

ORDER NO.	VERSION	PANEL THICKNESS	Color	HEIGHT	WEIGHT [kg]
PBS2-MP	2 die-cuts	1.2 mm, steel	black	2 U	0.600



x00264



Rack panel, with BNC holes

With 16 or 32 cutouts/ with 10 or 20 cutouts, respectively, for screwable standard BNC sockets, which are secured on the back with a lock nut.

ORDER NO.	VERSION	PANEL THICKNESS	COLOR	HEIGHT	WEIGHT [kg]
PBS1-B16	16-hole	1.2 mm, steel	black	1 U	0.300
PBS2-B32	32-hole	1.2 mm, steel	black	2 U	0.600



x00266



ORDER NO.	VERSION	PANEL THICKNESS	COLOR	HEIGHT	WEIGHT [kg]
PBA1-D06	6-hole	1.5 mm, steel	charcoal grey	1 U	0.320
PBA1-D08	8-hole	1.5 mm, steel	charcoal grey	1 U	0.300
PBA1-D12	12-hole	1.5 mm, steel	charcoal grey	1 U	0.140
PBA1-D16	16-hole	1.5 mm, steel	charcoal grey	1 U	0.130



x00268

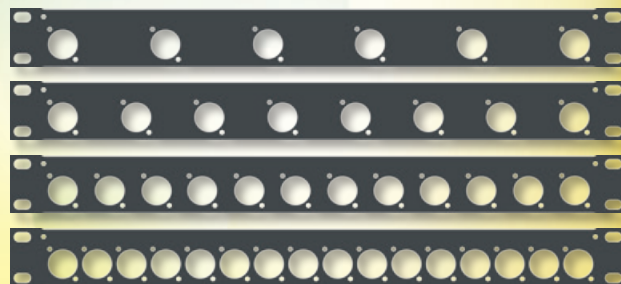

**CORNER VERSION
30° angled**

ORDER NO.	VERSION	PANEL THICKNESS	COLOR	HEIGHT	WEIGHT [kg]
PBA1-DA08	8-hole	1.5 mm, steel	charcoal grey	1 U	0.300
PBA1-DA12	12-hole	1.5 mm, steel	charcoal grey	1 U	0.140



x00272



ORDER NO.	VERSION	PANEL THICKNESS	COLOR	HEIGHT	WEIGHT [kg]
PBA1-B16	16-hole	1.5 mm, steel	charcoal grey	1 U	0.300



x00274



ORDER NO.	VERSION	PANEL THICKNESS	COLOR	HEIGHT	WEIGHT [kg]
PBQ1-D06	6-hole	4.0 mm aluminum	anodized charcoal grey	1 U	0.320
PBQ1-D08	8-hole	4.0 mm aluminum	anodized charcoal grey	1 U	0.300
PBQ1-D12	12-hole	4.0 mm aluminum	anodized charcoal grey	1 U	0.140
PBQ1-D16	16-hole	4.0 mm aluminum	anodized charcoal grey	1 U	0.130



x00276

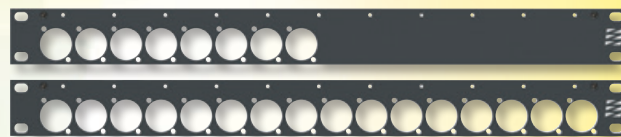

ORDER NO.	VERSION	PANEL THICKNESS	COLOR	HEIGHT	WEIGHT [kg]
PBQ1-B10	10-hole, including ZEPB strain relief	4.0 mm aluminum	anodized charcoal grey	1 U	0.300
PBQ1-B20	20-hole, including ZEPB strain relief	4.0 mm aluminum	anodized charcoal grey	1 U	0.300



x00277

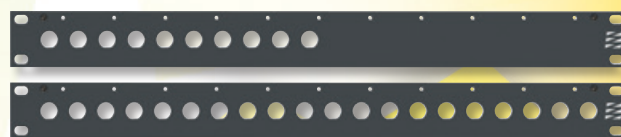

ORDER NO.	DESCRIPTION
1 M12-CAP-7016	Plastic cap for BNC holes, M12, color: RAL7016
2 M12-CAP-9010	Plastic cap for BNC holes, M12, color: RAL8010



x00278

Rack panel, with SUB holes

ORDER NO.	VERSION	PANEL THICKNESS	COLOR	HEIGHT	WEIGHT [kg]
PBA1-S258	8 x SUB-25	2.0 mm, steel	charcoal grey	1 U	0.300

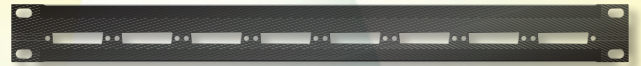

x00280

**Magnetic labeling strip**

suitable for the PBS and PBA series

ORDER NO.

ZSPB

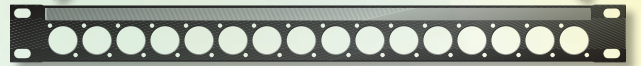

x00281

**Universal labeling strips with 443 mm/17.4" adhesive surface**

intended to be fitted with paper strips that are 9 mm/0.35" high. Overall height including carrier is 11 mm/0.43".

ORDER NO.

P19-BS09

HEIGHT

9 mm



x00283

**Number strips****ORDER NO.**

NSPB

VERSION

Numbering 1 - 32

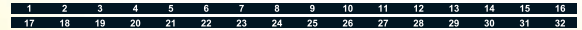

x00284

**Strain relief bar**suitable for the PBS series (required screws: **2xS-M2938**) and the PBA-/PBQ series (required screws: **2xS-M2953**)**ORDER NO.**

ZEPB



x00286

**Labeling profile**

suitable for the PBQ series for labeling strips, 6 mm/0.24" tall, Length = 106.5 mm/4.2", i.e. 21 sub units according to DIN

ORDER NO.

SYPS-12-MK2

set of 4 pieces



x00287

Multicore system components ▶ **PANEL HOUSING****PANEL HOUSING 19"**

for mounting 19" panels up to 4 U

ORDER NO.	VERSION	W x H x D [mm]
G1900	Empty housing 4 U high with die-cut for multi-pin connector panel on side, includes adapter panel with cutout for a PG21 cable gland/fitting.	483 x 180 x 60

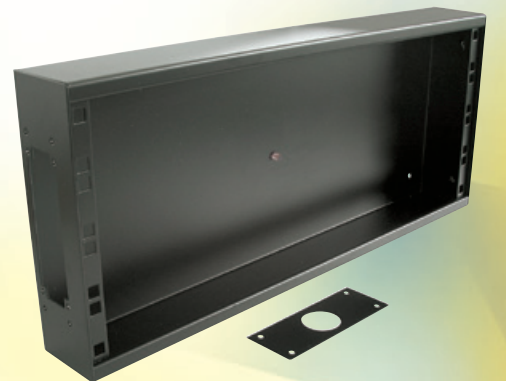

x00288

**19" FASTENERS**

ORDER NO.	CONTENTS
S-RACKSCREW	4 rack screws with 4 torsion-proof washers
S-RACKNUT-1	4 crown nuts for rack profile with clamping spring
S-RACKNUT-2	4 square tab nuts for simple rack profile
S-RACKNUT-3	4 captive nuts for 1.5 mm steel track of rack (suitable for G1900)
S-RACKNUT-4	4 captive nuts for 3.0 mm aluminum track on rack



x00289

Multicore system components ▶ Stagebox empty casings ▶ **PLUG MAMA MK II**

An extremely robust...

... and compact stagebox in a modern, well thought out panel design. Each box has punched holes for universal XLR connectors (e.g., NEUTRIK D-series), as well as **SOMMER CABLE** universal multipin holes for 16- and 24-pin rectangular and LK37-pin round connectors with the optional adapter plate AP-24-LK37. Many other adapters can be installed using the adapter panels shown on the next page.

APPLICATIONS:

- Live stage use
- Sub-distribution for keyboard or drums
- Fixed installation
- Permanent attachment to wall or floor

PRODUCT ADVANTAGES:

- Compact and chainable with a modern and ergonomic panel design
- No tripping over the connecting cable with the outlet located on the side
- Better overview even in bad lighting, with inputs clearly separated from outputs
- Extremely scratch-resistant with special double lacquered coating
- Large, clear numbering on inputs and outputs

PLUG MAMA, unpopulated

ORDER NO.	VERSION	H x W x D [mm]
900-0106	12 in / 4 out	145 x 165 x 308
900-0126	24 in / 8 out	145 x 263 x 308
AP-4D-B	Blank cover with 4 punched holes PLUG MAMA, required screws: 8xS-M2962 (please order separately)	
PM-LITE	Lighting set with 9 V compartment, LED green and switch for PLUG MAMA MK II	
S-M2962	M3 x 10 Torx panhead screw, black, for blank cover AP-4D-B (MOQ as Pack: 25 pcs.)	

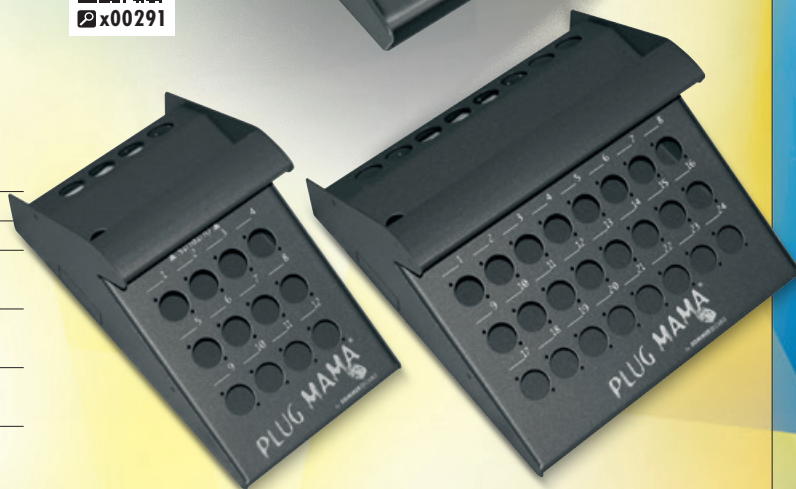

THE 19" SERIES

Go ahead, step on me, I can take it!

Heavy-duty and nearly indestructible 19" stagebox for studio and live application as well as permanent installation. The punched holes are intended for universal XLR connectors (e.g., NEUTRIK D-series) and imprinted with large numbers. The 19" flange on the side is removable for floor and wall installation. The front of the unit has 1 or 2 multipin panel holes for up to 2 adapter panels (BB1948 only).

For suitable XLR-modules with clamping connection for fast onsite installation, see chapter "Multicore & Power Distribution Systems".



Now available with 48 x XLR, 4 x multipin rectangular or 4 x LK round cutouts, 85 – 150 pin.
Note: Don't forget to order adapter panels!



Rainer Blanck

Our Series...

PLUG MAMA MKII, THE BOXX MKII and **SYSBOXX** are created in the same consistent **SOMMER** design.

* We equipped them with universal multipin holes for installation of all common rectangular multipins as well as a 24-, 25- or 37-pin LK or a PG29-output.

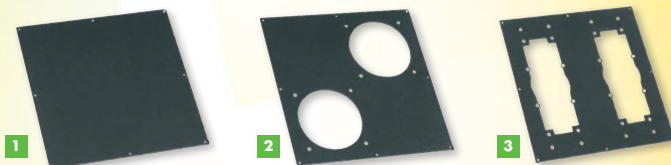

19" SERIES, empty housing

ORDER NO.	VERSION	W x H x D
BB1924N	24 holes/1 x multipin panel hole	19" x 4 U x 94 mm
BB1932N	32 holes/1 x multipin panel hole	19" x 5 U x 94 mm
BB1940N	40 holes/1 x multipin panel hole	19" x 6 U x 94 mm
BB1948N	48 holes/2 x multipin panel holes	19" x 8 U x 94 mm



Adapter panels for BB-series – please include in the order

ORDER NO.	DESCRIPTION
1 BB-AP-LB**	Blank cover
2 BB-AP-2LK**	Adapter panel for 2 x LK85/150
3 BB-AP-2MP**	Adapter panel with 2 universal slots for multipins *
S-G3010	M3 x 10 Torx10 countersunk screws for BB-AP plates (MOQ as Pack: 25 pcs.)



** Required screws: 8 x S-G3010 (please order separately)

Multicore system components ▶ Stagebox empty casings ▶ **THE BOXX – MKIII****THE BOXX** BY SOMMER  CABLE*A lot for your money...*

... is what you get with our reasonably priced floor stagebox **THE BOXX**. Each version of THE BOXX is made of powder-coated steel sheet metal of the highest quality in a practical stage design, topped off with a convenient carry handle. The universal D-holes are suitable for all connectors with common D-series shells. The 2-piece housing is solidly assembled with M3 counter-sunk screws (Torx), which also hold the 4 rubber feet in place. At the opposite end of the unit as the handle is a threaded cutout designed to accept any one of several different adapter panels for securing a multi-pin connector. This panel can hold 16- and 24-pin rectangular multi-pin connectors, or alternately, with optional adapter plate AP-24-LK37, a 37-pin round connector.

Many other multi-pin connectors can be attached to the housing using the adapter panels listed below.

APPLICATION:

- Live stage use
- Sub-distributor box, e.g. reel snake
- Fixed installation

PRODUCT ADVANTAGES:

- Excellent quality for the price
- Precision workmanship makes assembly a pleasure
- Broad choice of multi-pin connectors

We have decreased the distance between the XLR-holes on the new **THE BOXX MKIII Series** to allow simple and speedy pre-installation of our INSTA-modules (see chapter "Multicore & Power Distribution Systems").

 Made in Germany

TBH12 with AP-24-PG29

Standard opening for 16- and 24-pin multi-pin connectors

THE BOXX, unpopulated housing

ORDER NO.	DESCRIPTION	W x H x D [mm]
TBH08-MK3	THE BOXX 8 x hole D-type / output multipin 16/24/37 universal	195 x 211 x 80
TBH12-MK3	THE BOXX 12 x hole D-type / output multipin 16/24/37 universal	195 x 261 x 80
TBH16-MK3	THE BOXX 16 x hole D-type / output multipin 16/24/37 universal	195 x 311 x 80
TBH24-MK3	THE BOXX 24 x hole D-type / output multipin 16/24/37 universal	195 x 411 x 80
TBH32-MK3	THE BOXX 32 x hole D-type / output multipin 16/24/37 universal	195 x 511 x 80



x00295

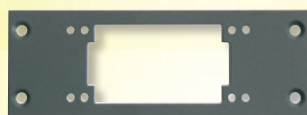

AP-24-10/06



AP-24-PG29



AP-24-LK37

Universal multipin adapter panel – also fits THE BOXX, PLUG MAMA MK II, and the 19"-series

Cutouts are flush, and threaded screw holes with M4 threads have been pre-drilled to accept and affix the multi-pin connector to the panel.

Required screws: 4 x S-M3935 (please order separately)

ORDER NO.	DESCRIPTION
AP-24-B	Blank cover for MP24
AP-24-10/06	Adapter panel MP24 ⇔ MP10/6
AP-24-PG21	Adapter panel MP24 ⇔ PG21
AP-24-PG29	Adapter panel MP24 ⇔ PG29 (for PG21 use RZG29-21)
AP-24-LK24	Adapter panel MP24 ⇔ CIRLK24 and CIRLK25
AP-24-LK37	Adapter panel MP24 ⇔ CIRLK37
AP-24-2D	Adapter panel MP24 ⇔ 2 x D-Type
AP-24-M40	Adapter panel MP24 ⇔ M40
AP-24-SIEM30	Adapter panel MP24 ⇔ Siemens type male/female, 30-pin
S-M3935	M4 x 10 Torx countersunk screw for AP-24 plates (MOQ as Pack: 25 pcs.)



x00296



TORX-SET-SBB

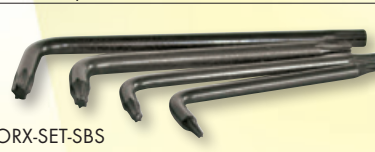

TORX-SET-SBS

Torx bit and pin wrench sets for installation of THE BOXX and SYSBOXX

ORDER NO.	CONTENTS
TORX-SET-SBB	Set of Torx bits: 6, 8, 10, 20
TORX-SET-SBS	Set of Torx wrenches: 6, 8, 10, 20



x00299



The **SCHILL GmbH & Co. KG**, located in Fellbach, Swabia, is the market leader in producing high quality cable reels for broadcasting, radio, live sound and electronic technologies as well as equipment for manufacturing sites and industries. Swabians like the Schill gentlemen (see photograph) are not only restless and resourceful inventors, but they are also very finicky. Therefore, cable reels made by **SCHILL** stand for absolute quality.

SCHILL cable reels are simply not comparable with some of the rickety reels available in the hobby sector – at an astonishingly small difference in price. Considering the quality, **SCHILL** reels are quite reasonably priced, thanks to their efficiently optimized production processes.

SOMMER CABLE is one of **SCHILL**'s largest customers and has a large product inventory. This makes us a favoured German contact address when it comes to fast product availability or professional cable equipment. Our technicians install audio, video, power and network cables on **SCHILL** reels (e.g., our portable **CARDINAL** reel with network switches). Please direct your request for **SCHILL** cable reels or special orders directly to **info@sommercable.com**.

Since 2007 **SOMMER CABLE** has been the official and exclusive distributor for **SCHILL** products in France. Most power outlets on **SCHILL** cable reels are also available in a French version.



Belt-driven and motorized reels in different sizes are available upon request. Special configurations are also possible!



In our B2B shop you will find the section "Cable Reels" below the corresponding bulk cable. Here the suitable cable reels are shown together with the maximum possible cable length.



Need a cable reel right now? Never a problem, as we keep all **SCHILL** products in stock at all times! Just give us a call: +49 (0)7082 / 491 33-0



GT310.MD4

IT266.MD3

CABLE REELS INCL. POWER OUTLETS

ORDER NO.	DESCRIPTION
GT310.MD4	Special rubber cable reel with 4 power outlets
IT266.MD3	Plastic cable reel with 3 power outlets

Prewired cable reels incl. power cable are available in the chapter "Multicore & Power Distribution Systems".



SIDE GUIDER FOR CABLE REEL

Round and round we go...

The **SIDEGUIDER** can be installed on the **SCHILL** cable reel **GT310** quickly and easily. It guides the cable from left to right during winding, distributing it evenly onto the reel. So the cable no longer has to be guided manually and one hand is free for holding onto the reel itself.

So you can, for example, walk up to the plugged cable with reel in hand and simultaneously wind the cable onto the reel with the help of the **SIDEGUIDER**. This practical time-saver is simply ideal for radio, TV and live sound.

ORDER NO.	DESCRIPTION
SIDEGUIDER1	Sideguider for SCHILL cable reel GT310 for cables with a diameter of max. 18 mm



HARDWARE & ACCESSORIES

Multicore system components ▶ **EMPTY REELS by SCHILL***Roll over Beethoven...*

... or anyone else for that matter. These are the official cable reels for musicians, soundmen, and broadcast technicians. The handle is constructed so that there is plenty of distance between you and the reel to prevent even the possibility of injury. These reels are resistant to chemicals, gasoline, and oil. All reels are equipped with a brake. They have a large winding core, a kink-free cable infeed, and an effective strain relief for sensible cable handling. Models GT310 and GT450 have a reel made of almost indestructible black solid rubber. It is especially recommended for everyday use on stage.

The GT310, GT380 and GT450 is now also available as SK310, SK380 and SK450 with stackable tubular steel frame and matching dolly (see accessories on the following pages).

You can download dimensioned drawings from our homepage www.sommercable.com. Here you can also find our cable length configurator to help you find out which reel is suitable for your cable length.

**The drums are delivered empty, i.e. without cable and no cover.
The complete SCHILL range can be found in our online shop!**



x00304

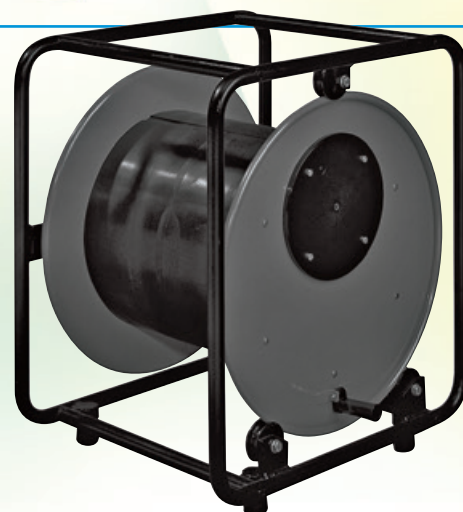

SK4822

**NEW!**

GT450

GT380

GT310

GT235



SK450

SK380

SK310

HT582 with KOMB.RM
(order separately)

**Stands for HT- and GT-series:
refer to the following pages**

HT480 with KOMB.RM
(order separately)

HT300K with KOMB.RM
(order separately)

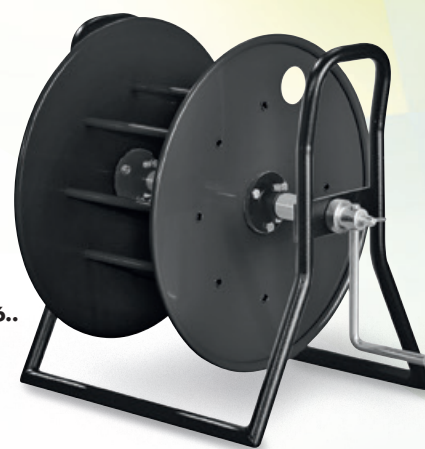

SK46..

**Dimension and cable capacity chart (cable length configurator – refer to www.sommercable.com)**

ORDER NO.	GT310, GT380, GT450,				HT300K	HT380	HT381	HT480	HT481	HT482	HT485	HT582	SK	SK	SK	SK
	GT235	SK310	SK380	SK450									4600.RM	4601.RM	4602.RM	4822
Outer-Ø [mm]	235	310	380	445	300	380	380	460	460	460	460	580	460	460	460	460
Core-Ø [mm]	135	170	236	296	178	178	240	178	240	320	178	320	280	280	280	320
Wind. width [mm]	110	132	182	187	142	142	170	142	170	170	210	170	250	350	500	336
Wind. length/max. [m]																
Ø 7.0 mm	60	135	249	301	120	243	232	400	392	292	600	609	487	696	988	585
Ø 8.0 mm	45	96	190	240	89	177	162	289	297	204	442	473	395	548	791	409
Ø 9.0 mm	34	73	153	185	67	143	122	225	235	153	345	355	313	440	638	315
Ø 11.0 mm	23	54	92	118	45	93	87	144	163	109	228	232	204	287	417	219
Ø 12.0 mm	20	41	86	104	41	76	67	121	137	85	187	197	162	235	332	170
Ø 13.0 mm	13	37	67	81	30	60	63	100	113	79	160	183	132	180	264	152
Ø 14.0 mm	12	33	62	75	30	60	58	100	91	73	150	152	118	174	243	146
Ø 15.0 mm	12	24	46	55	27	46	42	81	83	53	124	124	111	160	229	107
Ø 17.0 mm	6	21	38	51	18	34	38	64	65	48	96	98	81	116	168	92
Ø 20.0 mm	5	13	25	31	15	30	23	49	43	29	67	67	55	78	116	58
Ø 23.0 mm	4	11	20	27	9	20	20	36	30	25	50	50	34	52	73	51
Ø 25.0 mm	4	7	13	16	7	17	11	25	26	14	40	42	34	48	69	31
Ø 27.0 mm	2	6	11	13	7	13	11	25	26	14	34	34	31	41	62	29
Ø 30.0 mm	1	6	11	13	6	10	9	16	16	12	28	28	27	38	55	26

Multicore system components ▶ **COVER PANELS, TRANSPORT DEVICES***Rockin' and-a reelin'...*

... with the **SOMMER CABLE** cover panels in charcoal grey-coated 2 mm/0.08" sheet steel.

For our RUND-MP01 and RUND-MP02 models, we use the same multifunctional die-cut patterns for multi-pin connectors as with **THE BOXX MK II** and the **PLUG MAMA MK II**. Owing to the pre-cut M4 threads, installation is particularly quick and easy.

Matching adapter panels (such as LK37, Siemens, etc.) can be found a couple of pages further under "Adapter panels, THE BOXX".

In addition to the Schuko sockets the blue 3-pole CEE socket (Mennekes) can also be installed on the RUND0204 panel (using pre-cut M4 threads).

The large round panels RUND16 to RUND40 can be mounted directly on the reel using the RUND-FL. (Six holes with a pitch circle diameter of 27.5 cm/10.8" must be drilled into the reel).

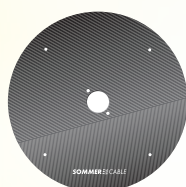
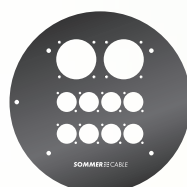
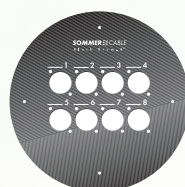
**RUND01****RUND0204****RUND0208****RUND04****RUND08****RUND12**

x00306

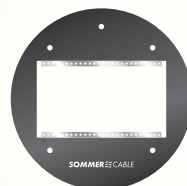
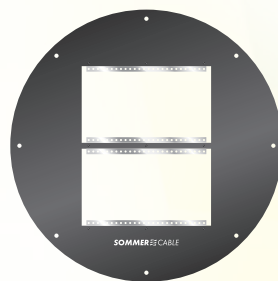
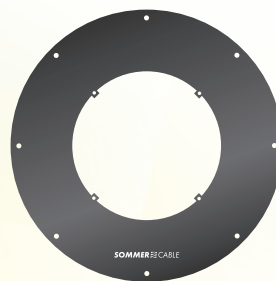
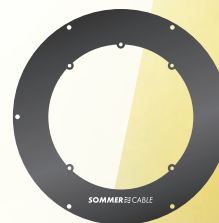
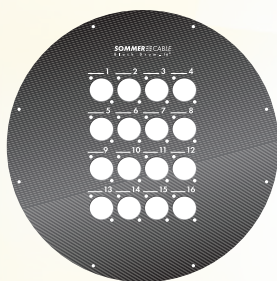
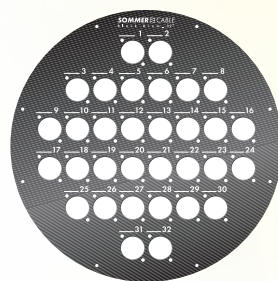
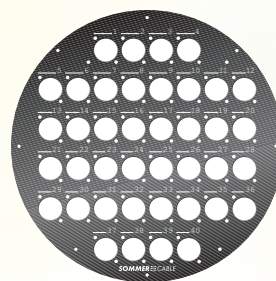
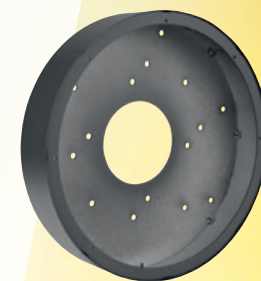
**RUND-LK85****RUND-MP2****RUND-SYS04****RUND-SYS08****RUND-AP****RUND-AP380****RUND16****RUND24****RUND32****RUND40****RUND-FL** **NEW!**

ORDER NO.	DESCRIPTION	
RUND01	Front panel with 1 D-hole (XLR, etc.)	Suitable for GT310, HT- and SK-model
RUND0204	Front panel with 2 Schuko- or CEE3-blue holes + 4 D-holes (XLR, etc.)	Suitable for GT310, HT- and SK-model
RUND0208	Front panel with 2 Schuko- + 8 x A/B holes (XLR A-Series)	Suitable for GT310, HT- and SK-model
RUND04	Front panel with 4 D-holes (XLR, etc.)	Suitable for GT310, HT- with core-Ø 240 and SK-model
RUND08	Front panel with 8 D-holes (XLR, etc.)	Suitable for GT310, HT- and SK-model
RUND12	Front panel with 12 D-holes (XLR, etc.)	Suitable for GT310, HT- and SK-model
RUND-LK85	Front panel with 1 LK-hole for LK85, LK150	Suitable for GT310, HT- and SK-model
RUND-MP01	Front panel with SOMMER universal multipin hole * (not shown)	Suitable for GT310, HT- and SK-model
RUND-MP02	Front panel with 2 x SOMMER universal multipin hole *	Suitable for GT310, HT- and SK-model
RUND-SYS04	Front panel with attachment for 4 WU SYSBOXX Front panels	Suitable for GT310- and HT-model
RUND-SYS08	Front panel with attachment for 2 x 4 WU SYSBOXX Front panels	Suitable for GT450- and SD-model
RUND-AP	Front panel with attachment for small round panels RUND0204, RUND-MP, etc.	Suitable for GT450, SD050 and SD060
RUND-AP380	Front panel with attachment for small round panels RUND0204, RUND-MP, etc.	Suitable for GT380
RUND16	Front panel with 16 D-holes (XLR, etc.)	Suitable for GT450, SD050 and SD060
RUND24	Front panel with 24 D-holes (XLR, etc.)	Suitable for GT450, SD050 and SD060
RUND32	Front panel with 32 D-holes (XLR, etc.)	Suitable for GT450, SD050 and SD060
RUND40	Front panel with 40 D-holes (XLR, etc.)	Suitable for GT450, SD050 and SD060
RUND-FL	Spacer flange for stagebox reel installation	Suitable for HT models (except HT300K-SW)

* Suitable adapter plates for PG29, LK37 and Siemens type male are available under "THE BOXX Accessories"

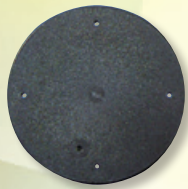

KOMB.SO



KOMB.450.RM



KOMB.RM



KOMB.RM-ALU

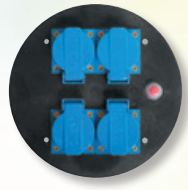

KOMB.MD4



KOMB.380.MFK



FS450



x00309

SK48

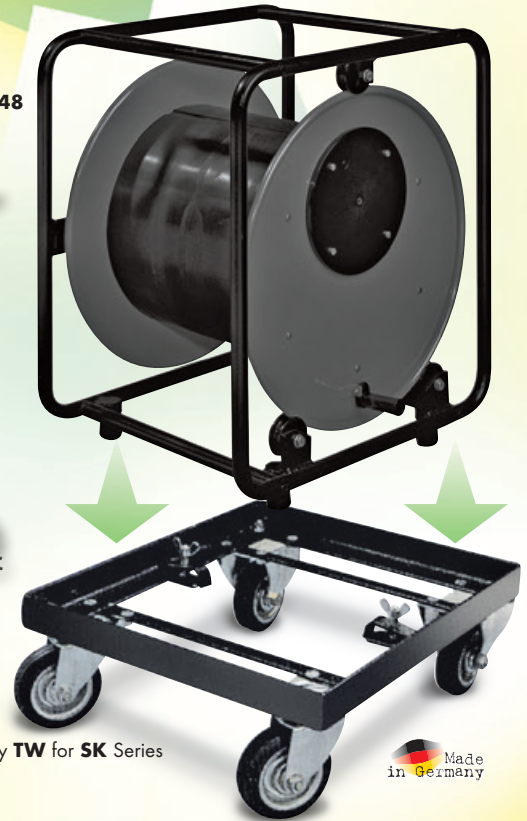

Trolley TW for SK Series

Made in Germany

ORDER NO.	DESCRIPTION	
KOMB.SO	Blank cover, plastic	Suitable for GT310, HT- and SK-model
KOMB.380.SO	Blank cover, plastic	Suitable for GT380-model
KOMB.450.SO	Blank cover, plastic	Suitable for GT450-, SD050 and SD060
KOMB.450.RM	Winding attachment, for cable fanouts	Suitable for GT450-model
KOMB.RM	Winding attachment, for cable fanouts	Suitable for GT310, HT- and SK-model
KOMB.RM-ALU	Winding attachment, metal	Suitable for GT310, HT- and SK-model
KOMB.310.MFK	Cover with lockable door	Suitable for GT310, HT-model and SK 302
KOMB.380.MFK	Cover with lockable door	Suitable for GT380 and SK 380
KOMB.450.MFK	Cover with lockable door	Suitable for GT450 and SK450
KOMB.MD4	Front panel with 4 power outlets	Suitable for GT310-, HT- and SK-model
TW-SK NEW!	Trolley for reel SK310 - SK450	Suitable for SK310, SK380, SK450
TW4600	Trolley for reel SK4600	Solid rubber wheels
TW4601	Trolley for reel SK4601	Solid rubber wheels
TW4602	Trolley for reel SK4602	Solid rubber wheels
FS450	Rolling cart for reel GT450	With height-adjustable steel pipe handle (see picture on the previous pages)
FST480	Rolling cart for reels HT480, HT481, HT482, HT582	

* Suitable adapter plates for PG29, LK37 and Siemens type male connector are available under "THE BOXX Accessories"

Cable reel accessories ▶ "BROADCAST"-EMPTY REEL SCHILL INCL. PROTECTIVE COVER

Close the door...

The **stackable** and **road-rugged** cable reel **SL500** was specially developed for applications in **professional broadcasting**. It has four **reinforced castor sockets** and is therefore particularly qualified for **robust use**. Furthermore, the reel is equipped with a **cover with a lockable door**, which protects the

connectors and keeps them easily accessible. An integral, **adjustable brake** prevents it from rolling away. The fixed, folding handles and a solid crank bracket are also practical.

Temperature range: -40°C to 130°C

External Ø: 450 mm

Core Ø: 250 mm

Winding width: 290 mm

Winding width:

CABLE	MAX. LENGTH
Ø 3 mm	3,450 m
Ø 7 mm	625 m
Ø 15 mm	124 m

ORDER NO.
SL500



x00310



Distribution Systems/racks/reels ▶ Stackable cable reels ▶ **CABLE REELS, STACKABLE***The tough rollers...*

... are gaining popularity, then with this roller despite the length of a cable, it can be transported just about everywhere.

These stackable cable reels are very reasonably priced. They are made of black 20 mm/0.79" thick steel piping and are mostly used to wind up heavy multipairs.

SD045-350



Each reel has a retractable handle and a compartment for cable end pieces and splices. The floor piping on all reels is pre-drilled for installation of all solid rubber rollers commonly available on the market.

Cable capacity chart, maximum length in meters

DIAMETER	SD045-350	SD045-440
12 mm	259	345
16 mm	132	181
20 mm	93	124
24 mm	64	86
28 mm	41	58
30 mm	41	55
32 mm	28	38



x00312

Weight	16 kg	17.5 kg
Dimensions in mm	530 x 450 x 480	680 x 450 x 480

Distribution Systems/racks/reels ▶ **CABLE REEL by SOMMER CABLE****SOMMER CABLE CABLE REEL, SOLID METAL***Reels on wheels...*

... because laying cable for the gig is easier when the reel is on wheels. This reel can be put to use wherever heavy multipairs with excessive length must be transported fast and safely.

The reel is available with our pre-punched XLR front panel "RUND16/32 and 40".

PRODUCT ADVANTAGES:

- Easy to move with a height-adjustable handle and large solid rubber wheels
- Clean and smooth run due to double suspension
- Even unwinding; variable brake
- Extremely long life with frame rack and retractable handle

APPLICATIONS:

- For OB vans and construction sites
- Can be converted to a stagebox

Cable capacity chart**MAX. LENGTH**

Cable-Ø 10 mm	440 m
Cable-Ø 15 mm	180 m
Cable-Ø 17 mm	137 m
Cable-Ø 22 mm	85 m

Outer dimension [WxHxD] 680 x 600 x 340 mm

Dimensions:

A	600 mm
B	315 mm
C	220 mm
D	302 mm

ORDER NO.

SD060

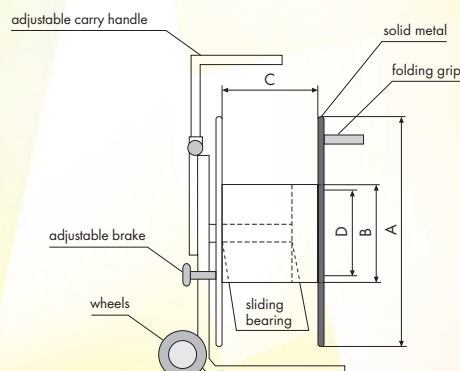

x00314

Cable winding equipment ▶ **FLOOR UNWINDING UNIT MISTER ROLLER**

For cable reels with a diameter of 12 to 120 cm/4.7" to 47.2" and a maximum roll width of 50 cm/19.7" (for larger roll widths two units can simply be set up side by side). A practical tool for construction site and industrial applications. The roll-stand is constructed of angled aluminum sheet metal, making it lightweight and cost-effective.

ORDER NO.**MISTER-ROLLER**

x00320

Made
in Germany
by
**sommer
TECHNIK**

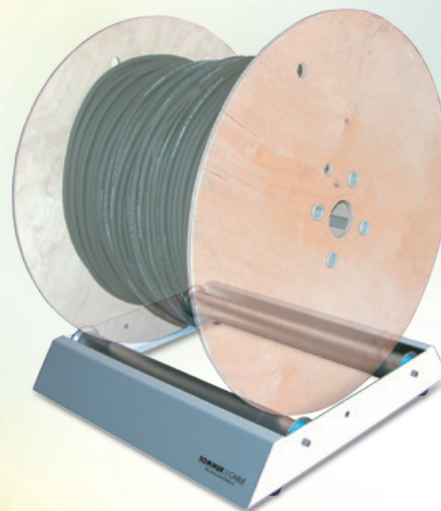
Cable winding equipment ▶ **PROFESSIONAL WINDER MISTER TWISTER**

Usually it's the women...

... who wrap the men around their little finger – but... here cables are "wrapped" around four fingers. One finger is movable toward the center for easy removal of the wound cable. You can unwind everything from a tight coil with an inside diameter of just 20 mm/0.79" to loose cable bundles measuring 300 mm/11.8" across. Cranking is done manually.

The advantage: The cable stays put and doesn't spill out towards the front. This enables simple and fast handling. The reel consists of a solid metal rack with 4 locking rollers, 1 deflection roller, 2 centering mandrels, 1 hand crank, and 1 winding plate.

The cable **meter counter** (order separately – Order No. MISTER-METER) measures the unwound length precisely.

A movable pair of **cutting scissors** (order separately – Order No. PC85) turns the winder into the perfect portable helper. If you work with the **floor roller** then the cable will run across a deflection roller (see picture on right). Having a second winding plate (MISTER-PLATE) would enable you to rewind from one ring of wound cable of one size to another ring of a different size. Everything has been thought of so that you can use it for all of your winding needs. It is small and handy, so it can be moved to wherever it is needed.

Plenty of advantages to make your long winding road easier. Winding-Ø from 150 – 270 mm/5.9" – 10.6" variably adjustable.

Max. winding width 150 mm/5.9";
W x H x D: 1110 x 1360 x 500 mm/43.7 x 53.5 x 19.7"
(patent pending)



x00317

ORDER NO.**MISTER-TWISTER****DESCRIPTION**

Professional winder

MISTER-PLATE

Replacement winding plate

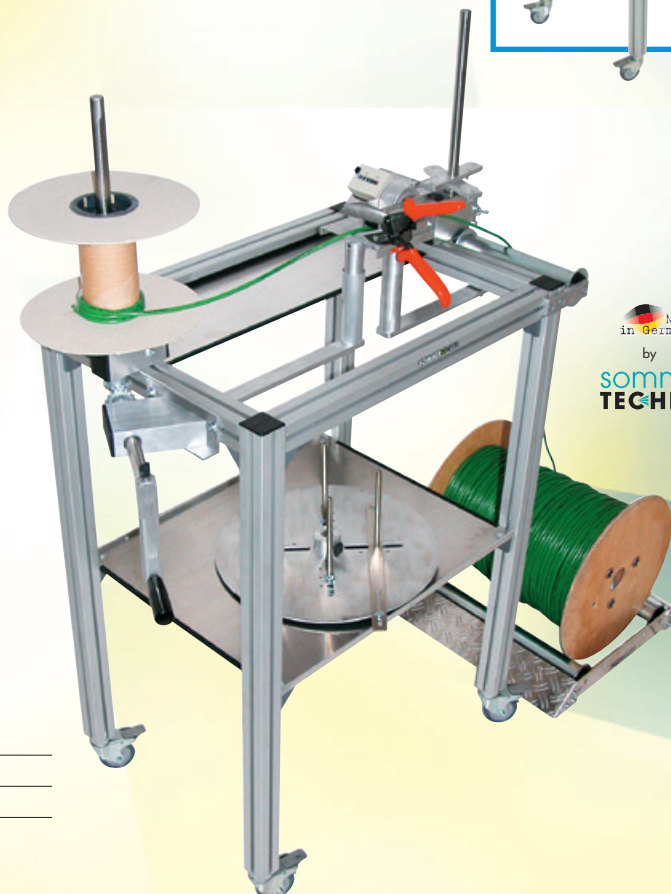
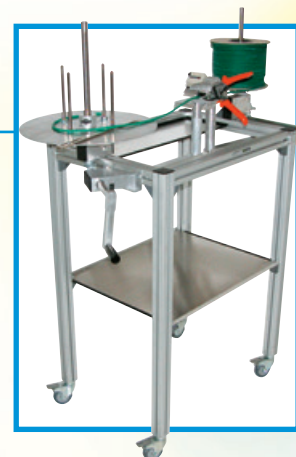

Made
in Germany
by
**sommer
TECHNIK**

Cable winding equipment ▶ **MISTER TROLLEY WINDER**

Unwinding and rewinding, compact and mobile



Fig. 1: Winding off the reel onto a ring – ideal for cable fabrication, shipping, or in-store sales. The winding-Ø can be adjusted from 150 to 270 mm/ 5.9" to 10.6". The meter counter* is not included, but is available as an option.

Fig. 2: Especially for installations often the cable must be laid out directly from the ring. Here the winding plate can simply be removed and then the ring with the spreading mandrel can be installed. During installation the length can be checked using the meter counter*.

Fig. 3: Reels can be unwound as well. Max. reel-Ø: 500 mm/19.7".



MISTER-TROLLEY is ideal for use on the construction site, in industrial settings, or for special cable sales. Handy and transportable like a trolley, it can be used in many different areas. As on all **SOMMER** working tools, the meter counter **MISTER-METER*** for length monitoring can be installed.

* **MISTER-TROLLEY** ships without the young man, cable and Mister Meter

ORDER NO.
MISTER-TROLLEY



Cable winding equipment ▶ **CABLE GUIDE MISTER GUIDE**

MISTER GUIDE...

... helps your cable or hose turn corners gently. It is very practical because it lets you unwind cables from several reels, rings or reels on a shelf directly onto a permanently installed winding or length measuring unit. Maximum diameter is 40 mm/1.6". Aluminum casing [W x H x D]: 94 x 94 x 12 mm/3.7 x 3.7 x 0.5". Two M6-threaded holes 63 mm/2.5" apart can be used to fasten the unit at a fixed location.

ORDER NO.	DESCRIPTION
MISTER-GUIDE	Cable and hose guide
MISTER-GUIDE-HLD	Table holder for a thickness of up to 40 mm

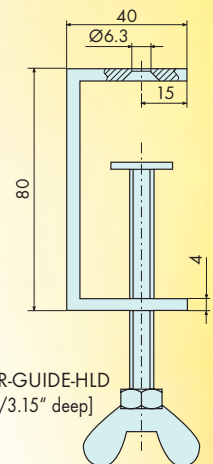

MISTER-GUIDE-HLD
[80 mm/3.15" deep]

Cable winding equipment ▶ **CUTTING SCISSORS POWERCUT + METER COUNTER MISTER METER****CABLE CUTTING SCISSORS**

Like butter...

... these scissors will cut even multiple multipairs of up to \varnothing in 28 mm/1.1". The **POWERCUT** is the sharpest pair of cable scissors we have ever seen. Thanks to the patented mechanics and the blade system even 48-pair multi-conductor cable can be cut easily and cleanly with only one hand. Replacement blades are also available.

POWERCUT – cutting length 75 mm/2.95"

ORDER NO.	DESCRIPTION
PC85	Cable scissors
PC85KL	Replacement blade



☒ x00324

CABLE LENGTH COUNTER

by the running meter...

For cables of up to 30 mm/1.18" in diameter our **MISTER METER** measures the cable length precisely. Without question – this practical device is fantastic, there is nothing better that is currently available. Before starting to measure you just reset the button to zero. The cable is pulled through, all you do is to read the required measurement and stop at the desired length. Also suitable as a hand or table unit. Robust, practical, and dependable. Tolerance: $\pm 2\%$.

Two adjustable restrainers ensure that the cable is guided evenly and prevent "swerving" or "slipping", which may lead to unsatisfactory measuring precision.

Cable length counter with removable handle.

ORDER NO.	W x H x D [mm]
MISTER-METER	142 x 104 x 132



☒ x00325

Cable winding equipment ▶ **UNWINDER TABLE UNIT MISTER TURNER**

It is not quite as versatile and convenient as **MISTER TWISTER**, but it is even more reasonably priced while fulfilling almost the same requirements.

The unit can be screwed to a table with 2 screws (or clamps). With the proper mounting bracket you can also install the unwinder on the wall. The ease of use will make this unit pay for itself in no time.

The optional cable length counter **MISTER METER** can be installed with the appropriate plug.

Winding- \varnothing : 150 – 270 mm,
variably adjustable
Max. winding width: 150 mm
W x H x D: 930 x 340 x 340 mm

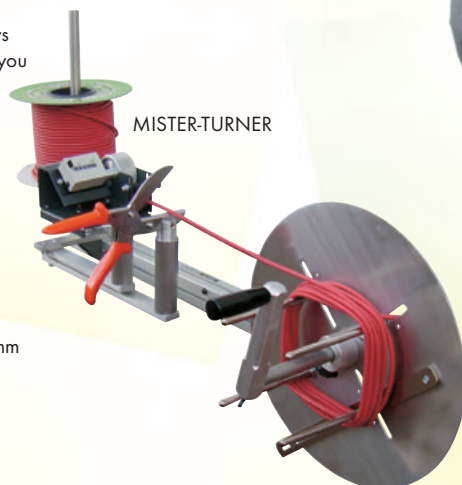

MISTER-TURNER



MISTER-TURNERSET

ORDER NO.	
MISTER-TURNER *	
MISTER-TURNERSET *	To wind from reel to reel



☒ x00327

* The **PC85 POWERCUT** cable shears is not included in the delivery. Please order separately – see above.

Cable management ▶ **PROTECTIVE BAGS**

No matter the shape...

... these protective bags will keep your multi-pin connectors safe from bangs, blows, spritzes, and other banes of the soundman's existence.

The bags are available in various sizes, and most can be retrofitted later. They fit all common multipin and LK connectors made by ILME, LK, HARTING, VEAM, AMPHENOL, etc.



ORDER NO.	SUITABLE FOR...
1 BAG-CAV-O	All MPs, straight output, later assembly
2 BAG-CAO-O	All MPs, side output, later assembly
3 BAG-CAO	All MPs, side output
4 BAG-LK-O	All LK cable plugs and sockets, later assembly
5 BAG-LKM-O	Round plug HI-LK08, HI-SOCA 19-pole, subsequent assembly possible
6 BAG-MINI-O	Round plug HI-FIBER4, EP5, Triax connectors 8-11, subsequent assembly possible
7 BAG-SIEM-O	30-pin Siemens type male/female + Triax connectors, later assembly
8 BAG-SPLICE	Splices up to 1.5 m in length, later assembly
9 BAG-BOXX	19" Stagebox 2 U, later assembly, ideal protection for stage sub-distributors + 19" components or stageboards



Studio & Stage Equipment / Accessories ▶ **CABLE PROTECTORS/CABLE BRIDGE/CABLE TAPE**

Unmercifully...

... that is how some supply cables are stepped on in crowds or flattened by the tour truck. These compact, low-profile, multi-channel modular cable protectors are the solution and offer optimum security for your cables.

Also they save you the time-consuming task of checking and sorting out the cables after the event. "So you can do it all again tomorrow!"

The cable channels are made of lightweight, impact-proof plastic with a yellow cover and comply with the applicable warning and safety norms.

The ideal "security" for all professional live-event technicians.

W x H outside: ... 535 x 50 mm

W x H inside: ... 5 channels 35 mm x 35 mm each

Weight: ... approx. 13 kg per m

Color: ... black with yellow cover

An inexpensive alternative is the cable guide tape, with both warning and identifying function.

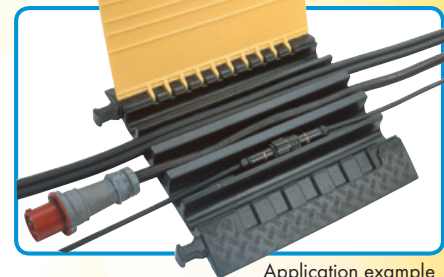
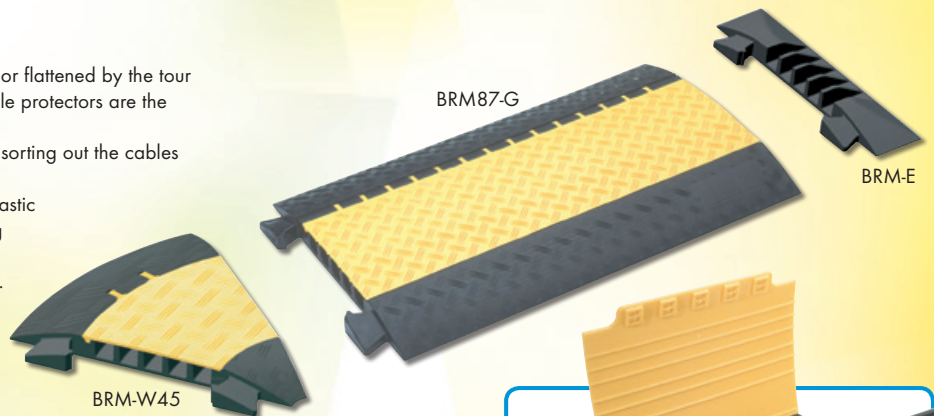

ORDER NO.	DESCRIPTION
BRM87-G	Cable channel straight, 870 mm
BRM-W45	Cable channel with 45° angle
BRM-E	End piece for cable channel
SCT145-GE/SW	Safety cable tape 145 mm x 30 m, with adhesive only on the outer edges





Cable management ▶ **GAFFGUN™ – The floor tape dispenser**

NEW!

The GAFFGUN-(R)Evolution

Do your employees feel tortured by tedious tasks from time to time? It all ends now!

The new **GAFFGUN** makes it obsolete to crawl on your knees to tape cables to the floor. Those days are officially over! With as many as 6 audio or video cables strewn about the floor you can easily take a relaxing walk and the **GAFFGUN** will center the cables and affix them with quality tape to the floor; or just simply put down warning tapes or cordon off a dancing area, and more!

Here's how:

There are several cable guides you can choose from, depending on the size and number of cables to tape down. Position the guide at the bottom of the GAFFGUN, and apply some pressure until it snaps into place. Then slide a roll of original GAFFGUN CoreLok tape over the orange-colored axle on the punched groove (in the tape core) over the snap-in nose of the axle and fasten until you hear it click. Pull the tape end through the slot below over the guide roller to the edge of the enclosure. The GAFFGUN is now "loaded". Pull a small length of tape out, manually tape it down over the cables at your desired starting point, and bring the GAFFGUN into place. Now it's time to „walk-n-roll,“ applying slight

downward pressure on the handle. At the end, simply cut the tape using the cutting edge of the GAFFGUN. The telescopic handhold can be loosened or drawn to the desired height. (Turning it clockwise will tighten it in place.)

Enjoy "shooting" with the (r)evolutionary GAFFGUN!

The GAFFGUN advantages:

- **Save** about 80% of your **time** compared to other tape-down methods!
 - **Lower your staffing expenses** (i.e. no need for additional stage hands)!
 - Unit includes a **molded foam inlay** for storage in a case!
 - **No more back or knee pain** and **no dirty hands!**
 - **Easy to maneuver** in circles or around corners!
 - Almost every commonly used tape is available in a **GAFFGUN** specific version!
 - Available as entry-level (**GAFFGUN-S**) and pro bundle (**GAFFGUN-PRO**) versions!
 - Adapter (**GAFF-AD**) for high quality standard tapes available!
 - No taunting remarks from your colleagues anymore!
- ...and finally – it just looks cool!

For videos and application examples, please visit www.gaffgun.com



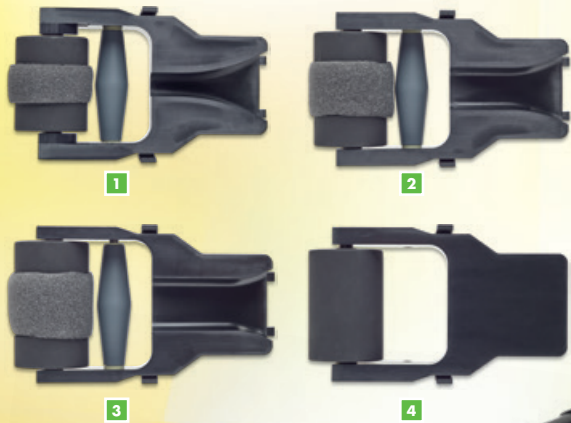

ORDER NO.	DESCRIPTION
GAFFGUN-PRO	GAFFGUN with all guides + handle
GAFFGUN-S	GAFFGUN with cable guide narrow + handle
1 GAFF-CG-S	Cable guide narrow 1.6 cm ^{1 2}
2 GAFF-CG-M	Cable guide medium 2.8 cm ¹
3 GAFF-CG-L	Cable guide wide 3.5 cm ¹
4 GAFF-FG	Guide for laying cable on very level floors ¹
5 GAFF-EH	Telescopic handgrip 47 - 73 cm ^{1 2}
6 GAFF-AD	Adapters for standard tapes (24 / 48 / 72 mm) ⁴
7 GAFF-ST-DUC2-SW	DUCT tape 48 mm x 50 m, black ³
8 GAFF-ST-DUC3-SW	DUCT tape 72 mm x 50 m, black ³
9 GAFF-ST-PRO2-SW	Pro tape 48 mm x 50 m, black matt, non reflective ³
10 GAFF-ST-PRO3-SW	Pro tape 72 mm x 50 m, black matt, non reflective ³
11 GAFF-ST-PDC3-SW	Tunnel tape 72 mm x 50 m, black matt, non reflective ³
12 GAFF-ST-DAN2-TR	DANCE tape 48 mm x 33 m, clear vinyl ³
13 GAFF-ST-DBL2-WS	DOUBLE SIDED tape 48 mm x 45 m, white ³



¹ included in GAFFGUN-PRO
² included in GAFFGUN-PRO and GAFFGUN-S
³ incl. CoreLok core for perfect laying, GAFF-TP carton package unit - see price list/shop
⁴ Only CoreLok tapes offer full functional warranty!

HARDWARE & ACCESSORIES

Cable manufacture ▶ **GAFFER TAPES, INSULATING TAPES**



Stick that...

... cable to your floor or lighting T-bar.

The manufacturer **ADVANCE** supplies a series of high quality tapes that are easy to tear off the roll, don't leave gummy deposits, and yet offer excellent adhesion.

- We offer Gaffer Tapes in three qualities, the **AT0165**, a standard adhesive tape with good adhesive properties, and the **AT0202**, free of residues for professional stage technologies and live sound.
- The original Gaffer Tape **AT0200** (fabric) is absolutely reflection-free and thus suitable for professional video technology.
- The warning tape **AT0008H** is yellow and black for identification of obstacles (stairways, tripods, etc.).
- The anti-slipping tape **AT2000** can be used as an anti-slipping base for stairsteps, ladders, etc.
- The **AT0307-CR** is a double-sided adhesive tape with a different adhesive power on each side. This makes it suitable for short term adhesion and removal without residue (e.g., for floor coverings on stage and at exhibition halls).
- For labeling (of mixing boards, etc.), you can use the **AT211-WS**. It is heat-resistant up to 80°C/176°F and can be removed without leaving behind residue.
- The electrical insulating tape **AT0007** is available in black, red, and grey, and as a rainbow pack with 10 different color rolls – see photograph.



AT0165-SI



AT0202

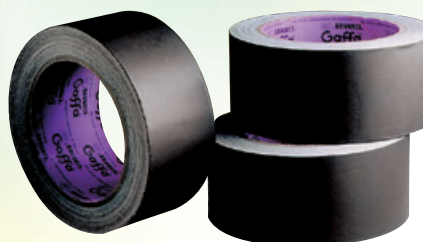

AT0200-SW



AT0008H-GS



AT211-WS



AT2000



AT0307 + AT0324



AT0007-RAINBOW



SOMMER-TAPES

APPLICATIONS:

Electrical, live sound, outdoors, security, churches, theaters, sets, film, video, construction, sanitary installation.

BEST QUALITY TAPES!

Adhes. strength	No residue	Non-reflective	Flame-retardant	Vertical tear	Water-resistant
++	+	-	+	+	+
++	+	-	+	+	+
++	+	-	+	+	+
++	++	-	+	+	+
++	++	-	+	+	+
++	++	++	++	++	++
++	+	-	-	-	+
++	-	++	-	-	++
++	++	-	-	-	+
+	++	+	-	-	-
++	+	-	++	-	++
++	+	-	++	-	++
++	+	-	++	-	++
++	+	-	++	-	++
++	++	-	+	+	+
++	++	++	++	++	++
++	+	-	-	-	+



x00333

GAFFER adhesive tapes

ORDER NO.	W x L [mm x m]	COLOR	Adhes. strength	No residue	Non-reflective	Flame-retardant	Vertical tear	Water-resistant
AT0165-SW	50 x 50	black	++	+	-	+	+	+
AT0165-SI	50 x 50	silver	++	+	-	+	+	+
AT0165-WS	50 x 50	white	++	+	-	+	+	+
AT0202-SW	50 x 50	black	++	++	-	+	+	+
AT0202-SI	50 x 50	silver	++	++	-	+	+	+
AT0202-WS	50 x 50	white	++	++	-	+	+	+
AT0200-SW	50 x 50	black, matt	++	++	++	++	++	++
Warning tapes								
AT0008H-GS	50 x 33	yellow/black	++	+	-	-	-	+
Non-slipping tapes								
AT2000-SW	50 x 18	black	++	-	++	-	-	++
Double-sided adhesive tapes								
AT0307-CR	50 x 25	creme	++	++	-	-	-	+
Labeling tapes								
AT211-WS	19 x 50	white	+	++	+	-	-	-
Electrical insulating tapes								
AT0007-SW	19 x 33	black	++	+	-	++	-	++
AT0007-RT	19 x 33	red	++	+	-	++	-	++
AT0007-GR	19 x 33	grey	++	+	-	++	-	++
AT0007-GR-15/10	15 x 10	grey	++	+	-	++	-	++
AT0007-RAINBOW	15 x 10	10 colors	++	+	-	++	-	++
SOMMER adhesive tapes								
ST0202-SW	50 x 50	black	++	++	-	+	+	+
ST0200-SW	50 x 50	black, matt	++	++	++	++	++	++
Warning tapes								
ST0008H-GS	50 x 33	yellow/black	++	+	-	-	-	+

TOP SELLER

Cable manufacture ▶ **REPAIR TAPES**

When things go wrong...

... you have a problem – and it's a good thing that some problems are easy to solve. This residue-free **SILICONE REPAIR TAPE** seals air, pressure and water leaks in seconds. You can easily stretch it like adhesive tape and wrap it around clean damaged areas. It is excellently suited for quick, durable cable and wire repairs, for bundling or as cable/plug or corrosion protection on metals – and it is ideal for use on the gripping surfaces of tools.

The clear version is particularly useful for additional labeling. The **SILICONE REPAIR TAPE** resists UV-radiation and oils, light acids and gasoline which makes it ideally suitable to insulate and repair cable jacketing, fuel lines, water and cooling hoses – e.g. when your car breaks down.

Tensile strength: 4.1 N/mm²
 Flexibility: max. 300%
 Isolation voltage: approx. 400 V at 1 mm/0.04" material thickness
 Temperature range: -55°C to +250°C / -67°F to +250°F

It should not be missing in any toolbox, household or vehicle.

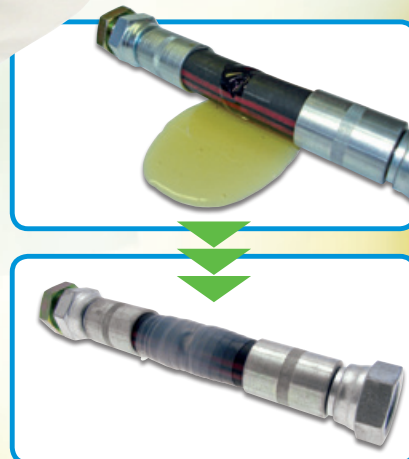
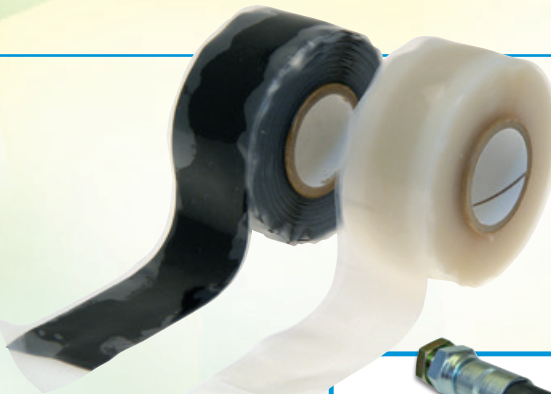

ORDER NO.	W x L	COLOR
SRT24-TR	24 mm x 3.6 m	transparent
SRT24-SW	24 mm x 3.6 m	black
SRT48-TR	48 mm x 10.9 m	transparent
SRT48-SW	48 mm x 10.9 m	black



Other colors are available upon request

Cable manufacture ▶ Heat-shrink tubing ▶ **INSULATING TUBING PVC**

By the running meter!

This insulating tubing can be used to protect multi-conductor wire pairs. The inside diameter of 3 mm/0.12" is ideal for almost all common foil-insulated multipairs. The insulating sheath is somewhat more robust, attractive, and much more reasonably priced than heat-shrink – and – it is much easier to pull over the wire

pairs. For holding the insulating tubing in place you can use shrink tubing BPDW, and for labeling the wire you can then use the heat-shrink tubing BP. The insulating tubing is available in black and in green.

Insulating tubing made of PVC

ORDER NO.	INNER-Ø	PACKAGING	COLOR
ABC10030401	3.0 mm	100 m	black



Cable manufacture ▶ Heat-shrink tubing ▶ **SHRINK TUBING WITH INSIDE ADHESIVE**

Long and thick!

This heat-shrink tubing made of radial polyolefine has an adhesive coating on the inside. It complies with MIL123053/4. The shrinking temperature is >120°C/248°F. The black shrink tubing is especially suitable for fanouts, splices, repair work, or connections that need to be strain-resistant. The transparent version is especially useful for labeling cables and plugs.

The shrinking rate is 3 : 1, making it suitable for almost all diameters of cable. This shrink tubing belongs in every professional's toolbox. Advantages: Watertight, labels do not slip, clean, attractive appearance.

Heat-shrink tubing lined with adhesive, length 1.20 m

ORDER NO.	Ø BEFORE SHRINKING	COLOR
BPDW120-12/04-SW	12.0 mm	black
BPDW120-18/06-SW	18.0 mm	black
BPDW120-24/08-SW	24.0 mm	black
BPDW120-39/13-SW	39.0 mm	black
BPDW120-12/04-TR	12.0 mm	transparent
BPDW120-18/06-TR	18.0 mm	transparent
BPDW120-24/08-TR	24.0 mm	transparent
BPDW120-39/13-TR	39.0 mm	transparent

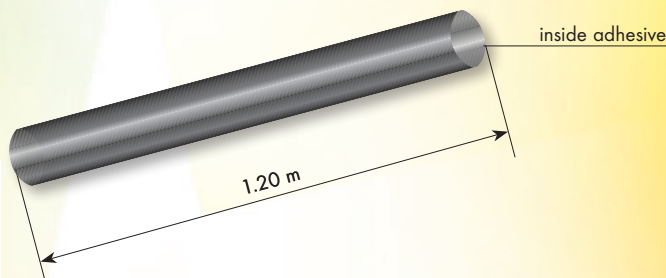

Universal heat-shrink tubing, incl. adhesive for repairs, length 0.25 m/0.8 ft., black, for Ø 10.0 – 35.0 mm/0.39 – 1.38".

Rough up the cable jacket... preheat it to approx. 60°C/140°F... place the sleeve around the damaged area... apply the compression clamp and heat up until adhesive begins to seep out. Then cut off any excess material.



ORDER NO.
BPDW026-SW

Cable manufacture ▶ **SHRINK TUBING****SHRINK TUBING SET, NUMBERED***These short...*

... pieces of shrink tubing are used for numbering and coding of multipair fanouts. The numbers from 0 - 9 can save you a lot of time and you will be able to identify immediately which channels are which. For 2-digit labeling you can simply slide two pieces of shrink tubing side by side. The shrinking rate is 3 : 1 with a final fixed length of 20 mm/0.79".

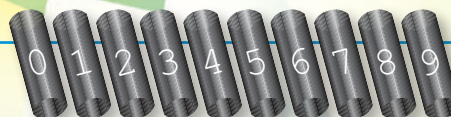
**Shrink tubing, numbered**

ORDER NO.	Ø BEFORE SHRINKING	CONTENTS
BP105-3,2x20	3.2 mm	50 pcs. (5 x 0 - 9)
BP105-10x20	10.0 mm	50 pcs. (5 x 0 - 9)



x00337

SHRINK TUBING SET, LABELED*Extremely practical...*

... are the shrink tubing sets for multipair fanout labeling.

The final fixed length of this shrink tubing is 90 mm, the shrinking rate 3 : 1.

For long-term readability in extreme conditions we recommend that a 120 mm/4.7" long piece of the transparent tubing BT-48/TR be used to cover the labels, or in the case of thicker cabling we recommend BT-95/TR.

Shrink tubing sets, labeled

ORDER NO.	Ø BEFORE SHRINKING	CONTENTS
BTN-CH01-08	Ø 4.8 mm (black)	Channel 1 - Channel 8
BTN-CH09-16	Ø 4.8 mm (blue)	Channel 9 - Channel 16
BTN-CH17-24	Ø 4.8 mm (black)	Channel 17 - Channel 24
BTN-CH25-32	Ø 4.8 mm (blue)	Channel 25 - Channel 32
BTN-CH33-40	Ø 4.8 mm (black)	Channel 33 - Channel 40
BTN-CH41-48	Ø 4.8 mm (blue)	Channel 41 - Channel 48
BTN-RT01-12	Ø 4.8 mm (red)	Return 1 - Return 12
BTN-SP01-04	Ø 9.5 mm (black)	Speaker 1 - Speaker 4



x00338

**PERSONALIZED HEAT-SHRINK TUBING***So unique and individual...*

... that's how your heat-shrink tubing can be. Use our printing service and order your individual shrink-on tubes with your own personal inscription or your company logo. Just send us your artwork as a jpg, tif, or eps file or vector graphic together with your order. The text length or logo width should not exceed 5 cm/1.97". The individually printable shrink-on tube sets are available in black with a diameter of 9, 15 or 29 mm/0.35", 0.59" or 1.14" and a length of 5 cm/1.97".

Shrink-on tubes, numbered

ORDER NO.	Ø BEFORE SHRINKAGE	MOQ AS PACK
PRINT-09-050-SW	Ø 9 mm (black)	10 pcs.
PRINT-18-050-SW	Ø 18 mm (black)	10 pcs.
PRINT-24-050-SW	Ø 24 mm (black)	10 pcs.



x00339

**Print Service**

Now we also offer individually imprinted heat-shrink tubing, incl. logo imprinting.

Cable manufacture ▶ Heat tubing ▶ **SHRINK TUBING in DISPENSER BOXES***Heatshrink in bulk*

The box holds very high quality, time-tested shrink tubing made of polyolefine in a handy form. The dispenser box is ideal for shop use or mobile applications.

The shrink tubing complies with the international specifications for professional use. The shrinking rate is 2 : 1. To obtain the final shrinking value you simply have to divide the pre-shrunk diameter by 2.

Available in colors - please add the **color code** to the order no.: black (**SW**), white (**WS**), red (**RT**), yellow (**GE**), blue (**BL**), green (**GN**), and transparent (**TR**). Order example: **BT-48/SW**

Shrink tubing in dispenser box

ORDER NO.	Ø BEFORE SHRINKING	CONTENTS
BT-12/Color	1.2 mm	12 m
BT-16/Color	1.6 mm	12 m
BT-24/Color	2.4 mm	11 m
BT-32/Color	3.2 mm	11 m
BT-48/Color	4.8 mm	10 m
BT-64/Color	6.4 mm	7 m
BT-95/Color	9.5 mm	6 m
BT-127/Color	12.7 mm	6 m
BT-190/Color	19.0 mm	5 m
BT-254/Color	25.4 mm	3 m



x00340

TECHNICAL DATA

Shrinking rate 2:1
Application temperature -55°C to +135°C / -67°F to +275°F
Flammability Fire-resistant and self-extinguishing
Shrinking temperature > 100°C/212°F
Disruptive strength > 20 kV/mm according to IEC 243
Specifications UL224 125°C, except transparent
Insulating material class B, according to VDE 0530



Cable management ▶ **VELCRO STRAPS**

Sticking like burs...

... these velcro ribbons will keep the wound up cable or other things in a firm grip. We offer two qualities, one for occasional use, the other for professional and frequent applications. The velcro straps with the tread-resistant PA plastic (KLE..P) or metal eyelet (KLE..M) are extremely robust and designed for **stage / event technicians**. The velcro straps with metal eyelet and the KLE13-200-..., KLE16M-200-..., KLE20M-250-... and KLE25M-300-... are available with adhesive flaps in black (**SW**), blue (**BL**), red (**RT**), green (**GN**) or yellow (**GE**). Please add color code to order number. Also available is velcro bulkware (hooked front side, fleece on rear side) to **secure cables within equipment cabinets** (fig. A) and to tidy up cable management (fig. B + C), and also self-adhesive, black edge protection tape (KLE..F) or velcro pads (Ø 47mm with hooks and fleece) – ideal for **stage and trade fair construction** and as scratchproof paddings for **enclosures and hifi components** (fig. D).

Customer logo print on request – see *

ORDER NO.	W x L [mm]	COLOR	MOQ AS PACK
KLE13-200-..	7 x 200	please state*	10 pcs.
KLE16M-200-..	16 x 200	please state*	NEW! 10 pcs.
KLE16MS-200-SW	16 x 200	black + SC logo	NEW! 10 pcs.
KLE20M-250-..*	25 x 250	please state*	NEW! 10 pcs.
KLE25-300-SW	17 x 300	black	10 pcs.
KLE25P-360-SW	25 x 360	black	10 pcs.
KLE50P-810-SW	50 x 810	black	10 pcs.
KLE25M-300-..	25 x 300	please state*	10 pcs.
KLE50M-500-GE	50 x 500	yellow	10 pcs.
KLE50M-800-GE	50 x 800	yellow	10 pcs.
KLE10-GN	10 x infinite	green	25 m
KLE20-SW	20 x infinite	black	25 m

Edge protection tape:
KLE19F-SW 19 x infinite black 15 m roll

Adhesive dots:
KLE47-SW Ø 47 - dots black 10 pair

* KLE16ML-200-... 16 x 200 individual logo print available at a premium
 * KLE20ML-250-... 25 x 250 beginning with a minimum order of 500 pieces
 * KLE25ML-300-... 25 x 300



Sample applications:



Fig. A

Fig. B

Fig. C

Fig. D

Cable management ▶ **CABLE TIES**

Who would have thought...

... that there are differences in quality among cable ties. Here we have compiled a small, suitable program with uncompromising elasticity and locking security.

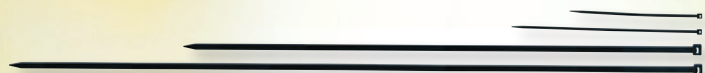

The "XXL" cable tie is 13 mm/0.51" wide, 750 mm/29.5" long and has a special detachable clasp. Hence the cable tie is reusable and particularly well suited for holding something in place temporarily yet absolutely securely (mechanical

Cable tie "XXL"

Polyamide, temperature range: -40°C to +85°C/-40°F to +185°F

Color and Order code: yellow: **GE**, black: **SW**

ORDER NO.	SIZE
KABI13-750-COLOR	13 x 750 mm

Cable ties, black – MOQ as Pack 100 pcs.

ORDER NO.	SIZE	MOQ AS PACK
KABI3,5-150-SW	3.5 x 150 mm	100 pcs.
KABI4,6-200-SW	4.6 x 200 mm	100 pcs.
KABI7,8-540-SW	7.8 x 540 mm	100 pcs.



resiliency: up to 888 N). Typical fields of application would be in building technology and electrical installation, many other applications – such as in horticulture, landscape gardening or scaffold building – are possible.

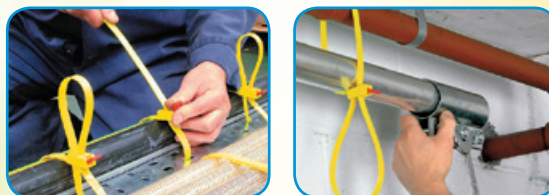

Cable management ▶ **NYLON SPLIT WIRE LOOMS**

A whole bundle...



... is held in place simply and efficiently for perfect organization and protection. It's easy to do with the special installation tool (please order separately) – ideal for control cabinets and line installation or for use in the office. The material is polypropylene. Temperature range: -60°C to +110°C/-76°F to +230°F, halogen-free, oil-resistant, self-extinguishing according to UL94HB, available in grey (**GR**), white (**WS**) or black (**SW**).

Please add color-code behind Order No.

ORDER NO.	NOM. SIZE	WALL THICKNESS
SPS16-..	16 mm	0.80 mm
SPS27-SW	27 mm	1.05 mm
SPS27-GR	27 mm	1.05 mm
SPS27-WS	27 mm	1.05 mm
SPS16-Tool	Installation tool for SPS 16-..	
SPS27-Tool	Installation tool for SPS 27-..	



Large gaps in the slotted area enable simple and clean branching.

Cable management ▶ **BRAIDED SLEEVING / CABLE SLEEVING***Wrap it up...*

... because the halogen-free, flexible and robust braided sleeving "GFS" not only has a tight grip on your cables – it also looks vastly more organized and aesthetically appealing than the jungle of vines that's currently growing at the back of your desk. We offer the braided sleeving in a closed version or with a side opening to allow for adding more cables in the future. The latter is available with a 25% overlap or Velcro on the side to allow for later removal or addition of more cables. The sleeving is available in white, silver or black, depending on the version. To avoid fraying, please note that the ends must be sealed with a hot wire after cutting.

Our service: You can order all versions in your desired length individually and with sealed ends. Minimum length: 1 m/3.3 ft.

Order code for your color choice:

■ black: **SW** ■ silver: **SI** □ white: **WS**

If not stated otherwise we deliver the hosing in black.

Closed version

Temperature range: -50°C to +150°C / -58°F to +302°F

ORDER NO.	DIAMETER	MAX. LENGTH/ROLL
GFS-200-COLOR	20 - 40 mm	50 m
GFS-400-COLOR	40 - 80 mm	50 m
GFS-550-COLOR	55 - 110 mm	50 m



x00344



black



white

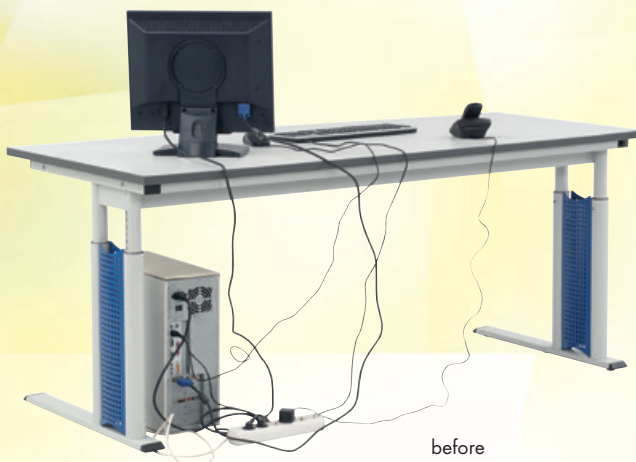

before



after

Open version with Velcro on the side

Temperature range: -10°C to +50°C / 14°F to +122°F

Order code for your color choice:

■ black: **SW** ■ silver: **SI** □ white: **WS**

If not stated otherwise we deliver the sleeving in black.

ORDER NO.	DIAMETER	MAX. LENGTH/ROLL
GFS-KLETT-Color	20 - 30 mm	50 m



x00345

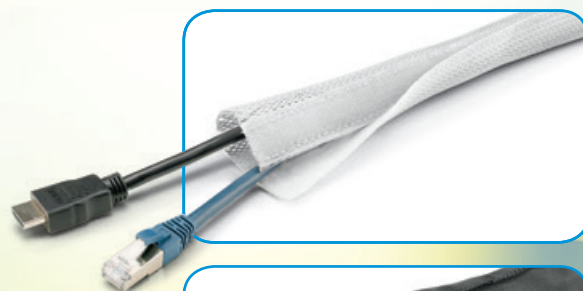

Open version with 25% to 50% overlap (depending on bundle diameter), only available in black. Temperature range: -70°C to +125°C

ORDER NO.	DIAMETER	MAX. LENGTH/ROLL
GFS-080-OPEN	5 - 8 mm	100 m
GFS-130-OPEN	10 - 13 mm	50 m
GFS-190-OPEN	16 - 19 mm	30 m
GFS-250-OPEN	19 - 25 mm	30 m
GFS-290-OPEN	25 - 29 mm	15 m
GFS-320-OPEN	29 - 32 mm	15 m
GFS-380-OPEN	32 - 38 mm	15 m



x00346



Cable management ▶ **CABLE RACEWAYS FOR PERMANENT INSTALLATION**

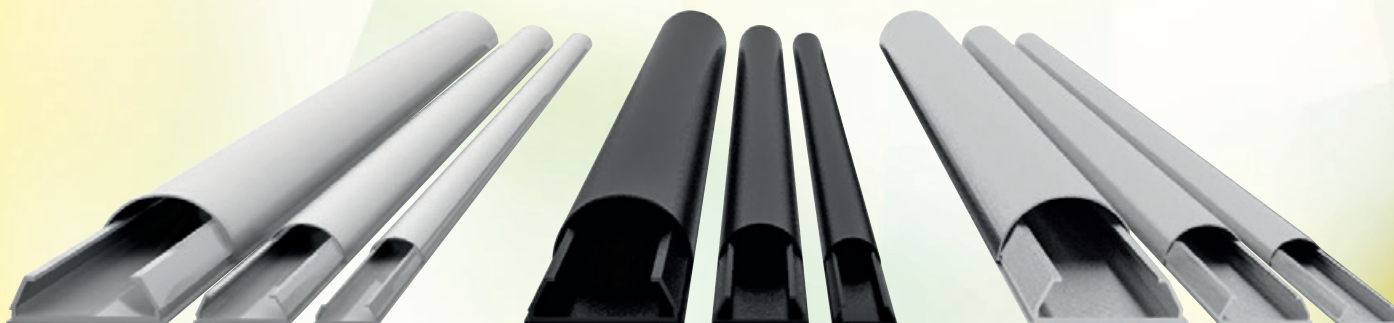

Full blast!

You can fill these half-rounded aluminum ducts with all kinds of cable for a clean professional appearance. A recipe for the successful elimination of your cable spaghetti: Just screw or glue the carrier rail to the floor, ceiling or wall, insert the cables and reattach the attractive cover. Finished!

Temperature range: -10°C to +50°C/14°F to +122°F

Order code for your color choice:

■ black: **SW** ■ silver: **SI** □ white: **WS**

ORDER NO.	WIDTH	HEIGHT	LENGTH
KFE-3-110-COLOR	33 mm	18 mm	110 cm
KFE-3-160-COLOR	33 mm	18 mm	160 cm
KFE-5-110-COLOR	50 mm	28 mm	110 cm
KFE-5-160-COLOR	50 mm	28 mm	160 cm
KFE-8-110-COLOR	80 mm	42 mm	110 cm
KFE-8-160-COLOR	80 mm	42 mm	160 cm



Adapter set for clean installation in corners including 1 x C- and 1 x L-adapter. Material: plastic

Order code for your color choice:

■ black: **SW** ■ silver: **SI** □ white: **WS**

ORDER NO.	WIDTH
KFE-CL3-COLOR	33 mm
KFE-CL5-COLOR	50 mm

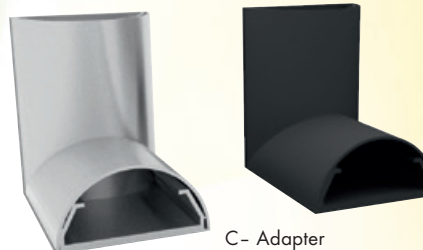

T-adapter. Material: plastic

Order code for your color choice:

■ black: **SW** ■ silver: **SI** □ white: **WS**

ORDER NO.	WIDTH
KFE-T3-COLOR	33 mm
KFE-T5-COLOR	50 mm



Installation / Conference ▶ **MOUNTING BRACKETS FOR SCREENS AND PROJECTORS***A tight grip and they won't slip!*

Whether you want to place your screen or projector on the ceiling, on a wall, a table or on the floor – our elegant, high-quality brackets will always keep a firm grip on your valuable media equipment.

In addition to the premium **STUDIO & HOME** range, we also offer our **CONFERENCE** brackets for ultimate quality and safety standards established for the highest demands of conference business.

STUDIO & HOME – Ceiling bracket

ORDER NO.	INCH	MAX. LOAD CAPACITY	WALL CLEARANCE	ROTATING ANGLE	TILT ANGLE	MAX. HOLE SPACING	VESA						ANTI-THEFT DEVICE	BUBBLE LEVEL	COLOR	
							50	75	100	200	400	200 x 100				400 x 200
H-BTV-TOP1-SI	23" – 37"	56 kg	-	-	+15° / -5°	515 x 320 mm	-	-	-	x	-	-	x	-	-	■
H-BTV-TOP2-SI	37" – 63"	80 kg	-	-	+10°	740 x 480 mm	-	-	-	-	x	-	x	x	-	■

STUDIO & HOME – Wall bracket

ORDER NO.	INCH	MAX. LOAD CAPACITY	WALL CLEARANCE	ROTATING ANGLE	TILT ANGLE	MAX. HOLE SPACING	VESA						ANTI-THEFT DEVICE	BUBBLE LEVEL	COLOR	
							50	75	100	200	400	200 x 100				400 x 200
H-BTV-WB1-SW	23" – 37"	50 kg	14.5 mm	-	-	400 x 400 mm	-	-	-	x	x	x	x	-	x	■
H-BTV-WB2-SW	32" – 50"	50 kg	14.5 mm	-	-	600 x 600 mm	-	-	-	-	x	-	x	x	-	■
H-BTV-WS1-SI	23" – 37"	75 kg	25 mm	-	-	425 x 330 mm	-	-	-	x	-	-	x	-	x	■
H-BTV-WS2-SI	32" – 63"	80 kg	25 mm	-	-	725 x 500 mm	-	-	-	-	x	-	x	x	-	■
H-BTV-WD1-SW	17" – 37"	50 kg	30 mm	-	-	200 x 200 mm	-	-	x	x	-	x	-	-	x	■
H-BTV-WD2-SW	23" – 42"	50 kg	43 mm	-	-	400 x 400 mm	-	-	-	-	x	-	x	-	x	■
H-BTV-WD3-SW	32" – 60"	50 kg	50 mm	-	-	600 x 400 mm	-	-	-	-	x	-	x	-	x	■
H-BTV-WF1-SW	10" – 40"	45 kg	115 mm	±45°	-5° / +20°	400 x 200 mm	-	x	x	x	-	x	-	-	-	■
H-BTV-WF3-SW	14" – 40"	45 kg	95 - 555 mm	3 x 180°	-5° / +20°	400 x 200 mm	-	x	x	x	-	x	-	-	-	■

CONFERENCE – Ceiling brackets for projectors

ORDER NO.	INCH	MAX. LOAD CAPACITY	WALL CLEARANCE	ROTATING ANGLE	TILT ANGLE	MAX. HOLE SPACING	VESA						ANTI-THEFT DEVICE	BUBBLE LEVEL	COLOR	
							50	75	100	200	400	200 x 100				400 x 200
H-BEA-TOP-SI	-	10 kg	100 mm	360°	±25°	-	-	-	-	-	-	-	-	-	-	■

CONFERENCE – Wall bracket

ORDER NO.	INCH	MAX. LOAD CAPACITY	WALL CLEARANCE	ROTATING ANGLE	TILT ANGLE	MAX. HOLE SPACING	VESA						ANTI-THEFT DEVICE	BUBBLE LEVEL	COLOR		
							50	75	100	200	400	200 x 100				400 x 200	600 x 400
H-FTV-WS-SW	32" – 49"	50 kg	23 mm	-	-	400 x 400 mm	-	-	-	x	x	x	x	x	optimum	x	■
H-FTV-WN-SW	46" – 63"	75 kg	45 - 148 mm	-	0 - 10°	900 x 600 mm	-	-	-	x	x	x	x	x	-	x	■
H-FTV-WF1-SW	26" – 37"	25 kg	43 - 140 mm	±45°	0 - 15°	200 x 200 mm	-	x	x	x	-	x	-	-	-	x	■
H-FTV-WF2-SW	26" – 42"	25 kg	47 - 225 mm	±45°	0 - 15°	400 x 400 mm	-	-	x	x	x	x	x	-	-	x	■
H-FTV-WF3-SW	26" – 42"	25 kg	49 - 455 mm	±90°	0 - 15°	400 x 400 mm	-	-	x	x	x	x	x	-	-	x	■

CONFERENCE – Wall bracket

ORDER NO.	INCH	MAX. LOAD CAPACITY	WALL CLEARANCE	ROTATING ANGLE	TILT ANGLE	MAX. HOLE SPACING	VESA						ANTI-THEFT DEVICE	BUBBLE LEVEL	COLOR		
							50	75	100	200	400	200 x 100				400 x 200	600 x 400
H-FTV-TS-COLOR	1 x 14"-24"	1 x 10 kg	-	360°	±15°	100 x 100 mm	-	x	x	-	-	-	-	-	-	-	■
H-FTV-TD-COLOR	2 x 14"-24"	2 x 10 kg	-	360°	±15°	100 x 100 mm	-	x	x	-	-	-	-	-	-	-	■

Installation / Conference ▶ "STUDIO & HOME" BRACKETS

**Ceiling brackets for flat screens
(LCD/Plasma/LED)**

23" to 37"

Max. load capacity: 56 kg

Tilt angle : -5° / +15°

Adjustable lengths: 380 to 630 mm (in 50 mm spacings)

Max. hole spacing: 515 x 320 mm

VESA Standard: 200 / 400 x 200 mm

Incl. anti-theft device



x00350

ORDER NO. **COLOR****H-BTV-TOP1-SI** silver

37" to 63"

Max. load capacity: 80 kg

Tilt angle : +10°

Adjustable lengths: 380 to 630 mm (in 50 mm spacings)

Max. hole spacing: 740 x 480 mm

VESA Standard: 400 / 400 x 200 / 600 x 400 mm

Incl. anti-theft device

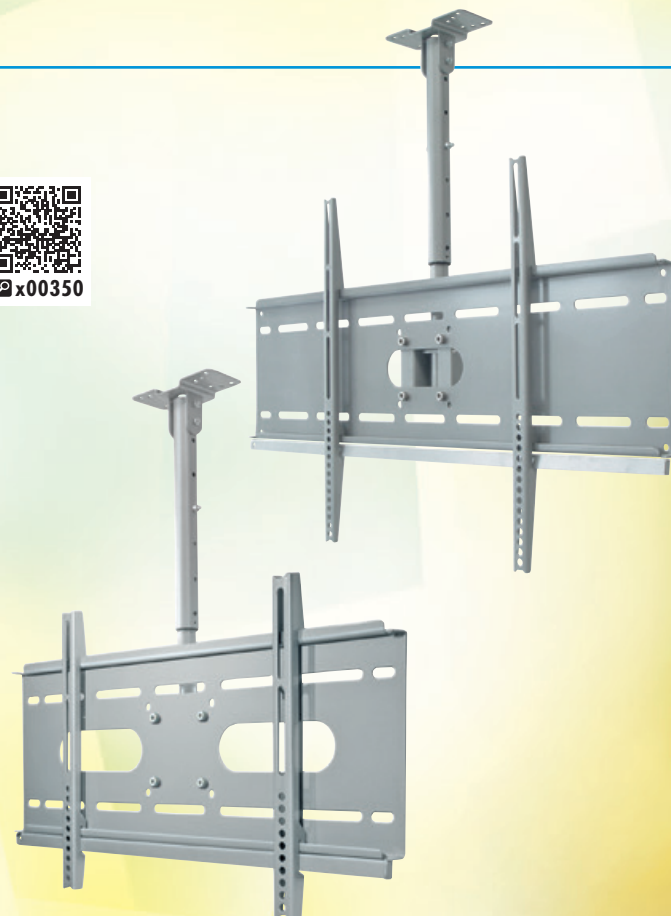
ORDER NO. **COLOR****H-BTV-TOP2-SI** silver**Wall brackets for flat screens
(LCD/Plasma/LED)**

23" to 37"

Max. load capacity: 50 kg

Wall clearance: 14.5 mm

Max. hole spacing: 400 x 400 mm

VESA Standard: 200 / 400 / 200 x 100 / 400 x 200 mm

Incl. bubble level



x00351

ORDER NO. **COLOR****H-BTV-WB1-SW** black

32" to 50"

Max. load capacity: 50 kg

Wall clearance: 14.5 mm

Max. hole spacing: 600 x 600 mm

VESA Standard: 400 / 400 x 200 / 600 x 400 mm

Incl. bubble level

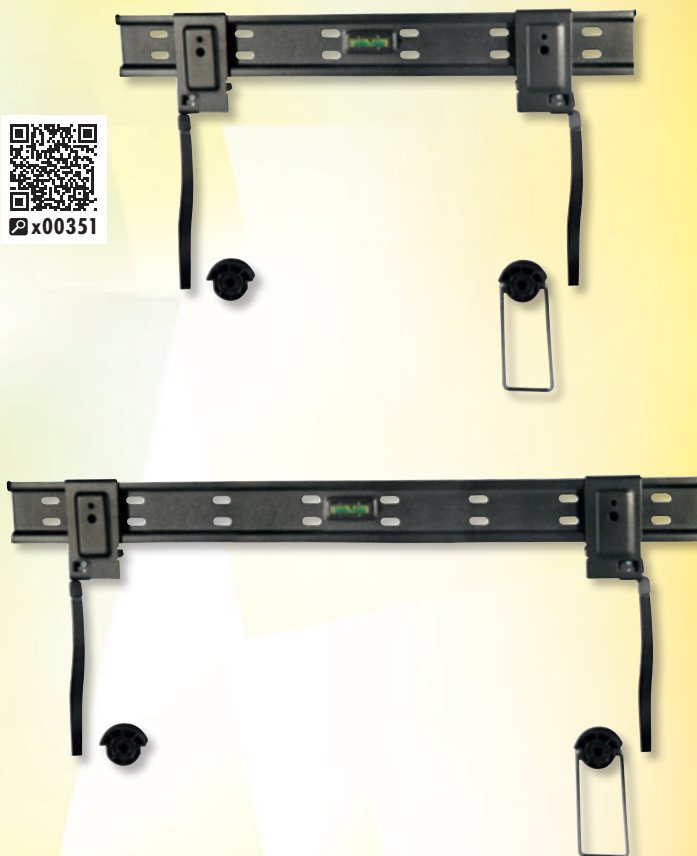
ORDER NO. **COLOR****H-BTV-WB2-SW** black

23" to 37"

Max. load capacity: 75 kg

Wall clearance: 25 mm

Max. hole spacing: 425 x 330 mm

VESA Standard: 200 / 400 x 200 mm

Incl. anti-theft device

Incl. bubble level

ORDER NO.	COLOR
H-BTV-WS1-SI	silver



x00352

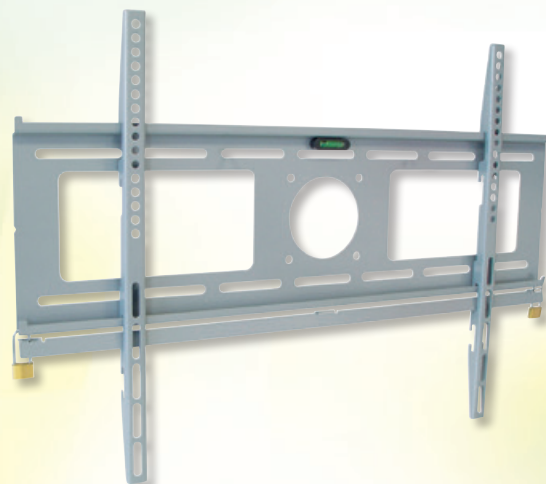
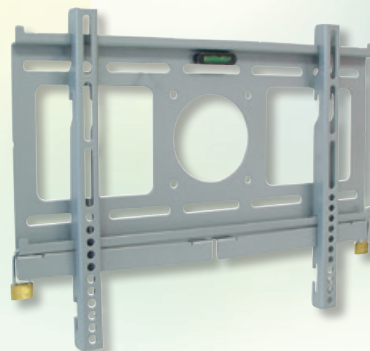

32" to 63"

Max. load capacity: 80 kg

Wall clearance: 25 mm

Max. hole spacing: 725 x 500 mm

VESA Standard: 400 / 400 x 200 / 600 x 400 mm

Incl. anti-theft device

Incl. bubble level

ORDER NO.	COLOR
H-BTV-WS2-SI	silver

17" to 37"

Max. load capacity: 50 kg

Wall clearance: 30 mm

360° horizontally adjustable

Max. hole spacing: 200 x 200 mm

VESA Standard: 100 / 200 / 200 x 100 mm

Incl. bubble level

ORDER NO.	COLOR
H-BTV-WD1-SW	black



x00354

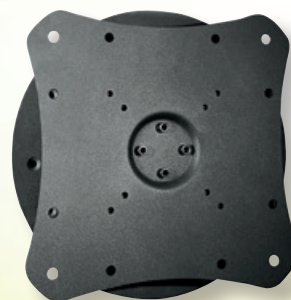

32" to 60"

Max. load capacity: 50 kg

Wall clearance: 50 mm

360° horizontally adjustable

Max. hole spacing: 600 x 400 mm

VESA Standard: 400 / 400 x 200 / 600 x 400 mm

Incl. bubble level

ORDER NO.**COLOR****H-BTV-WD3-SW**

black



x00354

23" to 42"

Max. load capacity: 50 kg

Wall clearance: 43 mm

360° horizontally adjustable

Max. hole spacing: 400 x 400 mm

VESA Standard: 400 / 400 x 200 mm

Incl. bubble level

ORDER NO.**COLOR****H-BTV-WD2-SW**

black

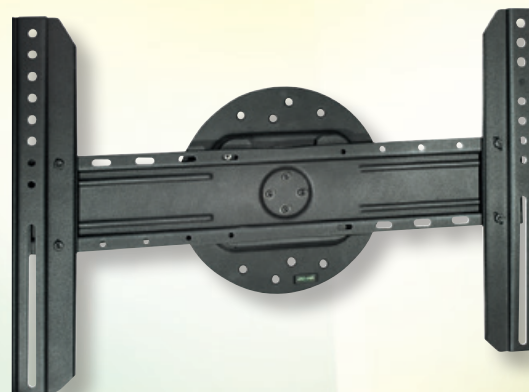

10" to 40"

Max. load capacity: 45 kg

Wall clearance: 115 mm

±45° swivel

20° horizontally adjustable

Tilt angle: -5° / +20°

Max. hole spacing: 400 x 200 mm

VESA Standard: 75 / 100 / 200 / 200 x 100 / 400 x 200 mm

ORDER NO.**COLOR****H-BTV-WF1-SW**

black



x00356

14" to 40"

Max. load capacity: 45 kg

Wall clearance: 95 to 555 mm

3 x 180° swivel

20° horizontally adjustable

Tilt angle: -5° / +20°

Max. hole spacing: 400 x 200 mm

VESA Standard: 75 / 100 / 200 / 200 x 100 / 400 x 200 mm

ORDER NO.**COLOR****H-BTV-WF3-SW**

black



Installation / Conference ▶ **MOUNTING BRACKETS****Ceiling projector mount**

Max. load: 10 kg

With pressure spring-ball joint-ceiling fixture

Dead weight: 5 kg

Incl. ceiling cover

Min. ceiling clearance 100 mm

Turnable by 360°

Tilting angle: -25° to +25°

Incl. adjustable universal fastener with safety screws and spacers

For all projectors up to 10 kg in weight

Color: silver



x00357

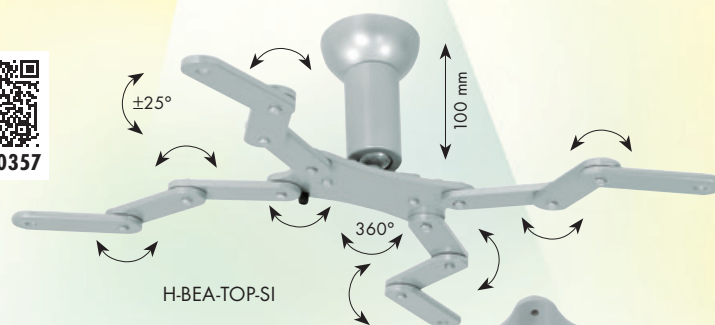

Six different optional extension adapters are available, both adjustable in length (including an internal cable guide) and fixed length. See chart below.

ORDER NO.	DESCRIPTION
H-BEA-TOP-SI	Ceiling projector mount
H-BEA-EF050	Extension, fixed length 50 cm
H-BEA-EF100	Extension, fixed length 100 cm
H-BEA-EF150	Extension, fixed length 150 cm
H-BEA-EV40/60	Extension, adjustable in length from 40 - 60 cm
H-BEA-EV60/100	Extension, adjustable in length from 60 - 100 cm
H-BEA-EV90/160	Extension, adjustable in length from 90 - 160 cm

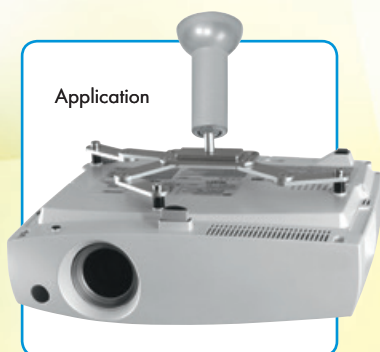

Application

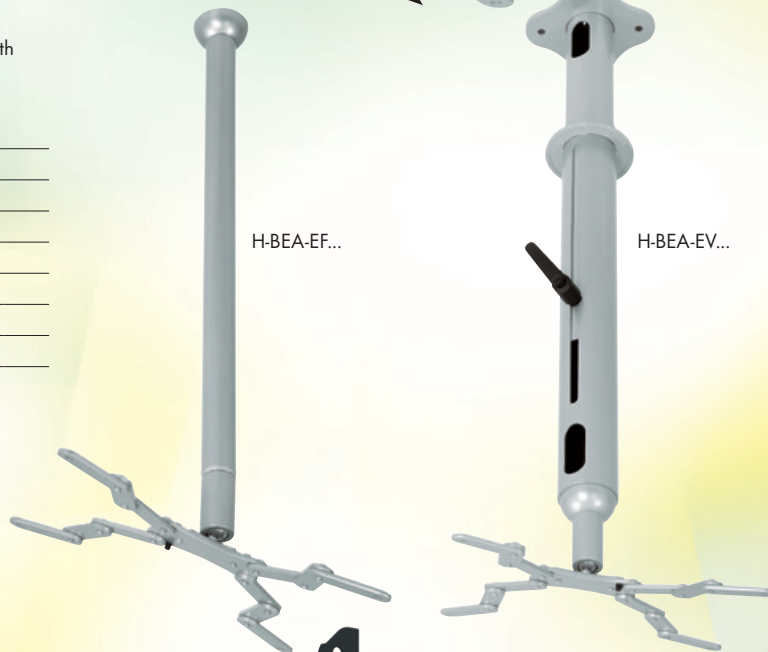
**Wall-mounting brackets for flat screens**

For flat screens from 32" to 49"

Max. load capacity: 50 kg

Wall clearance: 23 mm

Max. hole spacing: 400 x 400 mm

VESA Standard: 200 / 300 / 400 / 300 x 200 / 400 x 200 / 300 x 300 mm

Incl. bubble level



x00358

ORDER NO.	COLOR
H-FTV-WS-SW	black

For flat screens from 46" to 63"

Max. load capacity: 75 kg

Tilt angle: 0 - 10°

Wall clearance: 45 to 148 mm

Max. hole spacing: 900 x 600 mm

VESA Standard: 200 x 100 / 200 / 300 x 200 / 300 / 400 x 200 /

400 / 600 x 400 / 800 x 400 / 800 x 600 / 900 x 600 mm

Incl. bubble level

Incl. anti-theft device

ORDER NO.	COLOR
H-FTV-WN-SW	black



Wall mount for flat screens from 26" to 37"
 Max. load capacity: 25 kg
 Tilt angle: 0 - 15°
 Wall clearance: 43 to 140 mm
 Max. hole spacing: 200 x 200 mm
 ±45° swivel
 VESA Standard: 75 / 100 / 200 / 200 x 100 mm
 Incl. bubble level

ORDER NO.	COLOR
H-FTV-WF1-SW	black

Wall mount for flat screens from 26" to 42"
 Max. load capacity: 25 kg
 Tilt angle: 0 - 15°
 Wall clearance: 47 to 225 mm
 Max. hole spacing: 400 x 400 mm
 ±45° swivel
 VESA Standard: 100 / 200 / 400 / 200 x 100 / 400 x 200 mm
 Incl. bubble level

ORDER NO.	COLOR
H-FTV-WF2-SW	black

Wall mount for flat screens from 26" to 42"
 Max. load capacity: 25 kg
 Tilt angle: 0 - 15°
 Wall clearance: 49 to 455 mm
 Max. hole spacing: 400 x 400 mm
 ±90° swivel
 VESA Standard: 100 / 200 / 400 / 200 x 100 / 400 x 200 mm
 Incl. bubble level

ORDER NO.	COLOR
H-FTV-WF3-SW	black

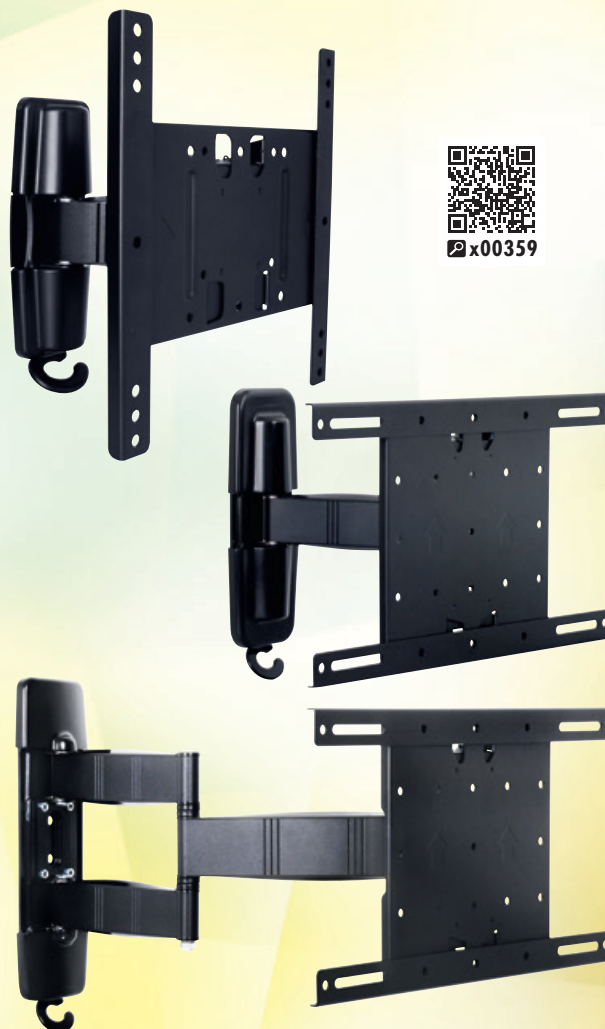

x00359

Desk mounts for flat-screen monitors (LCD/plasma)

1 x 14" - 24" or 2 x 14" - 24"
 1 x 10 kg or 2 x 10 kg
 Adjustable height
 Incl. adjustment function for horizontal and vertical format
 Turning/tilting and pivoting
 Table plate thickness up to 50 mm
 VESA Standard: 75 x 75 and 100 x 100 mm

Order code for your color choice:

■ black: **SW** ■ silver: **SI**

ORDER NO.	VERSION
H-FTV-TS-Color	Desk mount for one flat-screen monitor
H-FTV-TD-Color	Desk mount for two flat-screen monitors



x00360



before



after

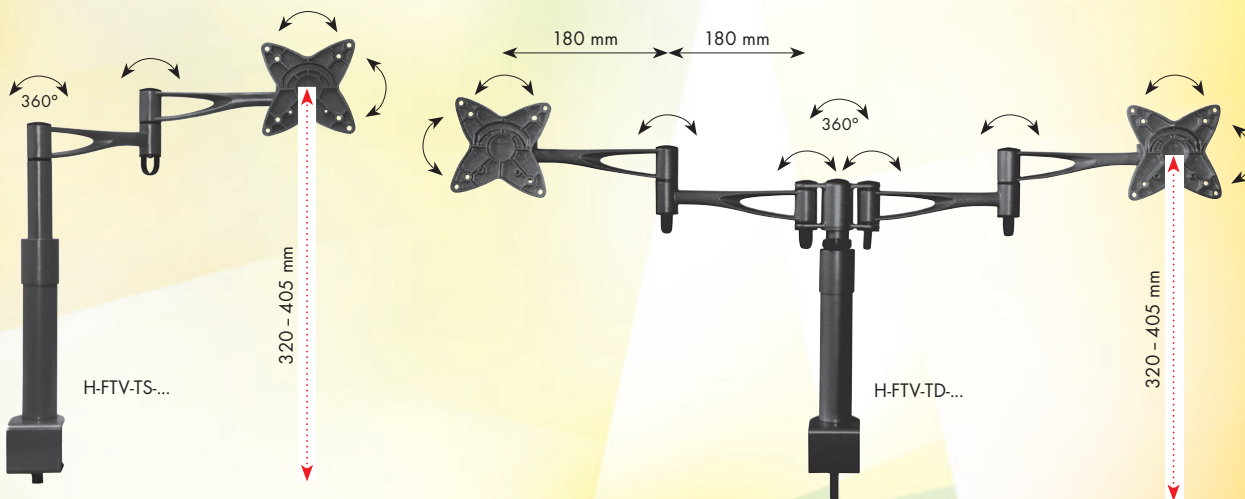

Cable manufacture ▶ **CABLE CLEANER***What a drag...*

... it is to wind or have to clean a messy, dirty cable.

From now on cable cleaning just became a lot easier.

You will really be surprised how this magic rag will remove all dirt. Even sticky, dried up dirt can be removed very easily. The cable will look like new and the **CABLE CLEANER** does not harm the cable in any way. The combination of the cleaning towel fibers and the special chemical cleaner make the **CABLE CLEANER** an outstanding product and a great help for a quick cleanup. The towels also last a long time. Make your life easier and save time in the process. Try it, you'll like it!



x00361



ORDER NO.	CONTENTS
CABLECLEAN	70 cleaning towels in a dispenser box

Cable manufacture ▶ **FLAT-SCREEN CLEANING SPRAY***Keep a clear view...*

... with our economical cleaning spray for monitors, TVs, tablets, smart phones and all other smooth surfaces. The handy spray bottle contains a 100% biodegradable, non-alcoholic cleaning agent that removes finger marks, dust, sticky deposits and other unwanted dirt, all without residue.

The cleaning spray is available as a set including a special microfiber cloth or as a single spray bottle.

ORDER NO.	DESCRIPTION
HI-TFT-CLEANSET	125 ml Spray bottle + 30 x 30 cm microfiber cloth (orange)
HI-TFT-SPRAY	250 ml Spray bottle



x00362

Cable manufacture ▶ **SPRAYS***Spray your problems away...*

... is exactly what these cans can. Order a whole set of these daily helpers and you'll be ready for anything.

ORDER NO.	APPLICATION	CONTENTS
SP-D	Dust Off - compressed air to blow dust away	400 ml
SP-T71	Freeze spray for cooling, locating electrical and electronic faults, testing of functions, thermostats, and TN start systems	400 ml
SP-SP	Fine cleaner for contacts NF-, HF-, UHF-range	400 ml
SP-T6	Contact spray to clean and maintain contacts, switches, relays, pots, transistors, etc.	400 ml
SP-LO	Label remover - safe on plastics	200 ml
SP-SI	Silicone spray - sliding and separating agent, care product for rubber, plastic and metal parts	400 ml
SP-SCL	Screen cleaner - for TFT and LCD monitors	200 ml



x00363



Installation ▶ **LED LIGHT – LEDLIGHT27 / LEDLIGHT2000**

Turn night into day...

... with the help of this practical LED light.

No construction site should be without the compact LED worklight **LEDLIGHT2000** with its nominal 2000 lumen. The worklight has a high-quality metal housing with a practical carrying handle and may be run either on a battery (2.5h) or a power supply.

ORDER NO.	L x W x H
LEDLIGHT2000	300 x 210 x 200 mm



x00364



LEDLIGHT2000

Cable manufacture ▶ **TOOLS**

 Made in Germany

Our strippers...

Based on a large number of customer requests, we now have a broad variety of cable jacket removal tools in our program. These handy and high quality sleeve and insulation removal tools are made of a special, absolutely non-breakable plastic. We have been using these multi-functional tools in our company for years and are thrilled about their dependability and how much easier they make many routine tasks.

ORDER NO.	DESCRIPTION
WAZ4	Cable stripper for cables and insulation with 0.08 – 10.0 mm ² , automatically self-adjusting
WAZ6	Stripping pliers for both flexible and solid wires 0.2 mm ² – 6.0 mm ² , stripping length 5 – 12 mm, also suitable for cables with PUR-jacket
WAZ-F	Stripping pliers for ribbon cables from 0.75 mm ² – 4.0 mm ² and round cables from 0.5 mm ² – 10 mm ² , stripping length 8 – 24 mm
WAA	Stripping tool for cable jackets and insulation with an adjustable stop
WKM28	Stripping knife for all round cables 4 – 28 mm ² incl. 2 fully retractable blades
WAM150	Stripping knife with flat tip, length 150 mm
WAP130	Stripping tweezers for fast removal of thin insulation
AIW13	Stripping tool for removal of cable sleeves and insulation sleeves 4.0 – 16.0 mm ² insulation 0.5 – 16.0 mm ²
LSA	Tool for soldering, screwing, and stripping + insertion tool for RJ45 with cutting function, incl. protective bag



WAZ10



WAZ6



WAZ-F



WAM150



WAA



WAP130



WKM28



AIW13



LSA



x00365



x00366

Screwdriver with 6-bit quick changer

This practical, handy screw driver with a 6-bit magazine is a must for every toolbox. Pull forward – turn – push back, you will find your desired bit in no time. Nothing gets lost, the bits are held in place magnetically and can be individually selected or replaced.

ORDER NO.	DESCRIPTION
WHS-6	Screwdriver with 6 bits



HTXP



WSW16



Insiders...

... know how hard it can be to tighten 30 XLR connectors. Often this is very cumbersome if it has to be done manually. Here is the suitable tool for efficient and comfortable assembly of XLR connectors made by NEUTRIK!

ORDER NO.	DESCRIPTION
HTXP	Assembly tool for Neutrik NC..XX and NP..X
WSW16	Assembly tool for sockets with SW16 in HI-DET

Cable manufacture ▶ WIRE END SLEEVES, SILVER SOLDER

WIRE END SLEEVES DIN 46228, Part 4, insulated

Installation adapter made of polyamide, resistant to temperatures up to +110 °C/230°F.

ORDER NO.	DIAMETER	COLOR	CONTENTS
AH1015	1 x 1.5 mm ²	black	100 pcs.
AH1025	1 x 2.5 mm ²	blue	100 pcs.
AH1040	1 x 4.0 mm ²	grey	100 pcs.
AH1060	1 x 6.0 mm ²	yellow	100 pcs.
AH1160	1 x 16 mm ²	blue	100 pcs.
AH2015	2 x 1.5 mm ²	black	100 pcs.
AH2025	2 x 2.5 mm ²	blue	100 pcs.



x00367



HICON SILVER SOLDER, HIGH PERFORMANCE

with 4% silver, lead-free according to DIN EN29453, Ø 0.5 mm/0.02", halogen-free, corrosion-free in compliance with DIN 8516.

ORDER NO.	COIL
HI-SILO-250	250 g



x00368

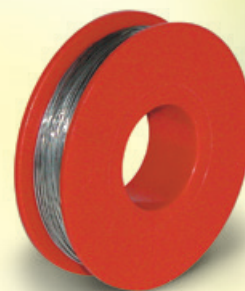

Cable manufacture ▶ **CRIMPING PLIERS**



ORDER NO.	DESCRIPTION	DIAMETER	AWG
1 HT-CRIMPSET	Universal crimping plier set for all coax-connectors (BNC), (Neutrik BNC not possible), incl. case (Spare pliers = HT-CRIMPPOOL)		
HT-1066	Crimping inset for BNC1.0/6.6-T and BNC 1.2/5.0-6G, suitable for HT-CRIMPSET		
2	Crimp pliers for ferrules, hexagonal crimping		NEW!
3	Crimp pliers for ferrules, square crimping		NEW!
4 WCZ1200	Professional crimping pliers, chrome, incl. case - without inserts		
5 WEC1232	Crimping insert for WCZ1200: cable lugs, not insulated	0.5 - 10.0 mm ²	20 - 7
6 WEC1260	Crimping insert for WCZ1200: cable lugs, insulated	0.5 - 6.0 mm ²	20 - 10
7 WECLOC1271	Crimping insert WEC1271 incl. locator for WCZ1200: twisted contacts, 4-corner crimping	0.14 - 4.0 mm ²	25 - 11
WEC1272	Crimping insert for WCZ1200: twisted contacts, 4-corner crimping	1.5 - 6.0 mm ²	15 - 10
8 WEC1286	Crimping insert for WCZ1200: RJ45 connectors		
9 WCZ1632	Crimping pliers for cable lugs, not insulated	0.5 - 10.0 mm ²	20 - 7
10 WCZ1660	Crimping pliers for cable lugs, insulated	0.5 - 6.0 mm ²	20 - 10
11 WCZ1671	Crimping pliers for twisted contacts, 4-corner crimping	0.14 - 4.0 mm ²	25 - 11
WCZ1672	Crimping pliers for twisted contacts, 4-corner crimping	1.5 - 6.0 mm ²	15 - 10
12 WCZ1690	Crimping pliers for wire end sleeves, 5-corner crimping	0.5 - 6.0 mm ²	20 - 10
WEC1299	Crimping die for WCZ1200: NLFASSTON und SB-FLACHSTV-6.3, incl. positioning facility	1.5 - 2.5 mm ²	15 - 13
13	Table mount for WCZ1200; for fatigue-proof working		NEW!



ORDER NO.	DESCRIPTION	HEX Crimp [mm]	
		SHIELD	JACKET
14 WCZ1201	Professional crimping pliers, chromed - without inserts		
DIE-R-BNC-PDC	Crimping insert for Neutrik BNC*	6.47	4.53
DIE-R-BNC-UG	Crimping insert for Neutrik BNC*	6.47	5.00/7.36
15 DIE-R-BNC-PJ	Crimping insert for Neutrik BNC*	6.47	5.41
DIE-R-BNC-PS	Crimping insert for Neutrik BNC*	6.47	7.01
DIE-R-BNC-PY	Crimping insert for Neutrik BNC*	6.47	8.23
DIE-R-BNC-Z-PLUS	Crimping insert for Neutrik BNC*	9.73	9.73

* Fits WCZ1200 and WCZ1201



Cable manufacture ▶ **PROFESSIONAL FIBER TOOLBOX**



DESCRIPTION	ORDER NO.
16 Professional toolbox for HI-FIBER4 system containing: Syringe, canula, AlcoPads, fiber stripper, stripping tool, aramid scissors, epoxy adhesive, polishing foils and disc, drying cabinet, microscope 200 x, etc.	HI-WLC-SET
17 One-click cleaner for fiber-optic plugs, also in recessed position, without deinstallation	FIBERCLEAN
18 200 Cleaning wipes for all optical fiber ends	FIBERWIPES



Cable manufacture ▶ **MEASURING INSTRUMENTS****HDMI® CABLE TESTER**

The **HD-T** cable tester allows you to check HDMI® cables for throughput and function, ideal for all self-assembled connections. Using the sweep function the pin assignments are also displayed. Transmitter and receiver can be detached to check already laid cables. The 9 V battery for the transmitter is included.

ORDER NO.**HD-T**

x00371

CABLE TESTER MCT-SC*Trust is good...*

... verifying is better.

It is good to have a mobile instrument available to test XLRm/f, SpeakON, phone jacks, RCA, DIN, RJ45 and USB connectors. The enclosed test leads enable universal testing on all other connectors of any kind. The display operates with LED and buzzer. Power is supplied by 2x AA batteries, which are easy to access and replace.

ORDER NO.**MCT-SC**

Less noise • More sound

**ORDER NO.****NTI-MR-PRO**

Description: Enhanced analog audio generator

Features/data: Frequency range: 10 Hz - 20 kHz

Output level -20 to +18 dBu

Sine wave/square wave signal up to 5 kHz

White/pink noise

Polarity signal

Sweep with adjustable duration

Source impedance 12.5 Ω

Runtime test signal

DC + USB-connection

THD+D -96 dB

XLR and RCA output

3 x AA batteries (operating time: 10 h)

NTI-MR2

Description: Analog audio generator

Features/data: Frequency range: 10 Hz - 20 kHz

Output level -76 to +8 dBu

Sine wave/square wave signal up to 5 kHz

White/pink noise

Polarity signal

Sweep with adjustable duration

Source impedance 200 Ω

Runtime test signal

DC + USB-connection

THD+D -90 dB

XLR and RCA output

3 x AA batteries (operating time: 20 h)

NTI-XL2

Description: Analog audio and acoustic analyzer

Features/data: Sound level meter Leq, Lmin, Lmax, Lpeak, Live

Frequency weighting: A, C, Z (= unweighted)

Time weighting: Fast, Slow

Monitoring of sound level limit values

Recording of WAV files (24 bit, 48 kHz, ADPCM) and short comments

Digital I/O interface to control external facilities

Realtime spectrum analysis RTA: 1/3, 1/1 octave band

Sound level Impulse-weighted average sound level, sound exposure level LAE

High-resolution zoom FFT with resolutions down to 0.4 Hz from 5 Hz - 20 kHz

Reverb time RT60 in 1/3 octave resolution



Less noise • More sound

**NEW!****ORDER NO.****NTI-ML1**

Description: Analog audio analyzer

Features/data: Level measurement in V, dBu, dBV

Frequency measurement

THD+N distortion factor

Noise measurement

1/3 Octaves

Control range ppm

Scope function

Polarity testing, time sweep

NTI-MINISPL

Description: Measurement microphone for AL1 & ML1

NTI-M2211

Description: Measurement microphone for NTI-XL2

Features/data: 1/2" diaphragm omnidirectional free-field microphone

Class 1 frequency response according to IEC 61672-1

Individual frequency response available as Excel file

48 V DC phantom power

Electronic data sheet installed

Frequency range 5 Hz - 20 kHz

Dynamic range 19 - 144 dB

NTI-M4260

Description: Measurement microphone for NTI-XL2

Features/data: 1/2" diaphragm omnidirectional free-field microphone

Class 2

48 V DC phantom power

Frequency range 20 Hz - 20 kHz

Dynamic range 29 - 144 dB

More NTI-products and -sets are available in our dealer pricelist.